



**American
Autowire**

www.americanautowire.com 856-933-0801

1987-89 Ford Mustang
Classic Update Series
510547

DESIGN ASSISTANCE
PROVIDED BY:

LATEMODELRESTORATION.COM

© COPYRIGHT 2004 American Autowire / Factory-Fit
Used with express permission of
American Autowire / Factory-Fit

START HERE !

PLEASE READ THIS BEFORE STARTING INSTALLATION !

This wiring kit is designed for ease of installation. Please read the guidelines below, BEFORE STARTING your installation, to guarantee a successful job. Use an appropriate crimping tool, which folds the wings of the open barrel terminals down into the wire, as shown on this page. If you use our crimping tools and correctly crimp the included terminals, soldering is not necessary. If you are unsure about a particular crimp, soldering is recommended. Our factory crimped terminations are installed by GM approved five ton presses, and soldering these terminations is not necessary.



AAW offers a great terminal crimping video entitled "Proper Crimping Video". It can be viewed by visiting YouTube.

Type the following address into your web browser, to go directly to the video:
www.youtube.com/watch?v=JAgEDoVI-co

Youtube Channel:
www.youtube.com/user/WiringHarness



The terminals that we supply in our kits, utilize what is known as an F crimp. The F crimp, in a cross section, will look like the illustration below, when done correctly.

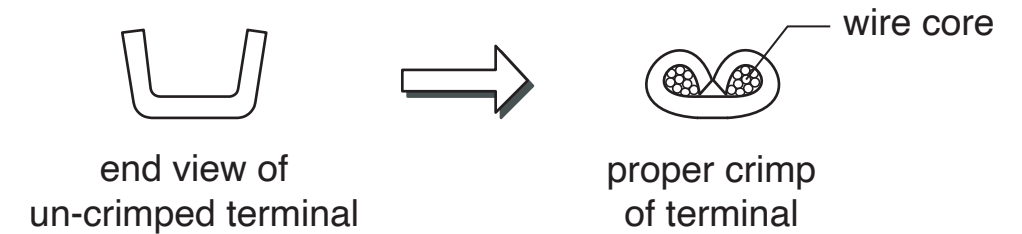

We carry the following crimping hand tools, to help with your terminal crimping. These hand tools are available, for purchase or rental.

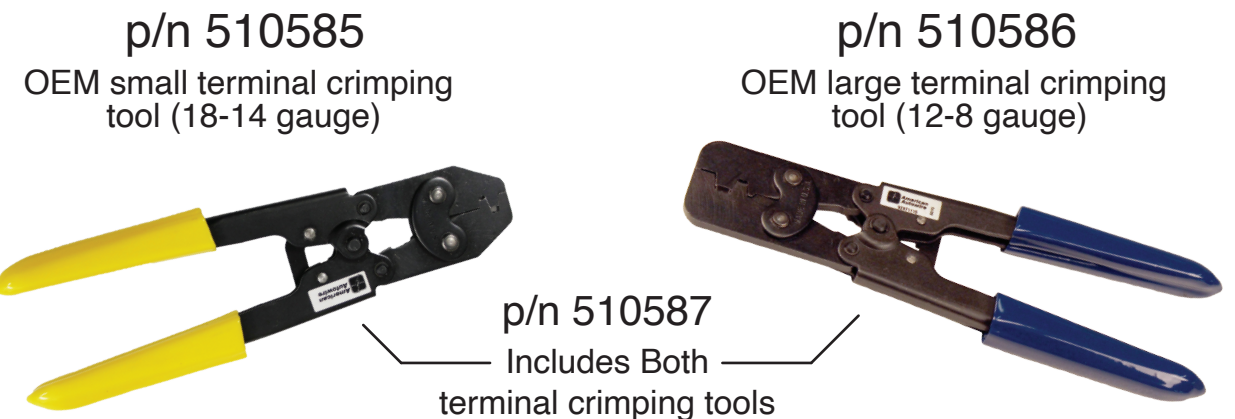

We carry many accessories for your 1987-89 Ford Mustang.

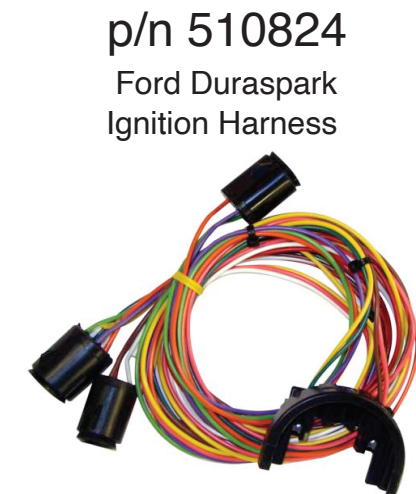

STEP 1: DISCONNECT YOUR BATTERY:

Disconnect the battery, before installing the wiring kit, to prevent any accidental shorting caused by loose bare wire ends.

If you have any questions concerning this or any of our products, please feel free to call us at 1-856-933-0801.

1987-89 Ford Mustang
Classic Update Series

STEP 2: START INSTALLING KIT:

This kit is broken down into individual sections, that are identified by a letter printed on the enclosed sheets, visible through each bag. The order of installation and the pages with their installation instructions, are shown below:

Table of Contents:

Bags: Pages: Sections:

G	4 - 14	Dash Harness - This is the main harness in the kit and contains: <ul style="list-style-type: none">- Starter solenoid connections.- Wiper motor connections- Brake light switch connection.- Neutral safety switch connection.- Door jamb switches.- Wiper module and switch connections- Defrost module and switch connections.- Headlight and fog light connections.
H	15, 16	Gauge Cluster Harness - This Harness contains: <ul style="list-style-type: none">- Gauge connections for aftermarket gauges.
M	17, 18	Rear Body Harness - This Harness contains: <ul style="list-style-type: none">- Tail light, turn signal, reverse light, and running light connections.- Hatch connections; third brake light, license plate lights, and rear defroster connections.- Fuel pump connections.
L	19 - 22	Front Light Harness - This Harness contains: <ul style="list-style-type: none">- Headlight, turn signal, running light connections.- Fog lamp wiring.- Windshield washer connection.- Electric fan relay trigger.- Brake fluid level wiring.
J	23 - 25	Engine Harness - This Harness contains: <ul style="list-style-type: none">- Temperature, oil pressure, tachometer wiring.- Ignition system / ECU power.- A/C compressor connections.- Alternator connections.



Connector terminal removal instructions:

You will need to remove the terminals, from the connectors that are to be salvaged from your original harnesses. Looking into the openings in the mating end of the connector, you will need to push the small latches inside, towards the outside of the connector body, while gently pulling the wire and terminal, from the other end. Be careful not to break the latches.

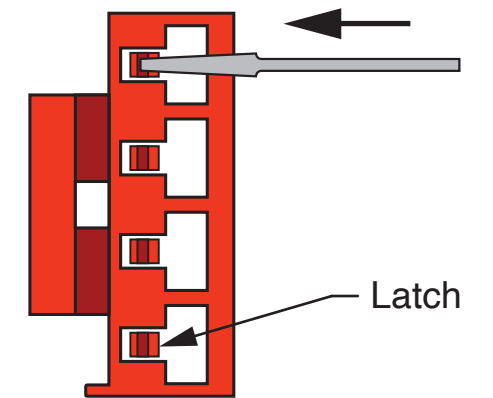

The white Defrost Module connector to the right, needs to have the black retaining strip removed, prior to pushing the latches, to release the terminals. This retaining strip will be replaced, after the new terminals are installed. If the strip should break, during removal, the connector will still work without it.

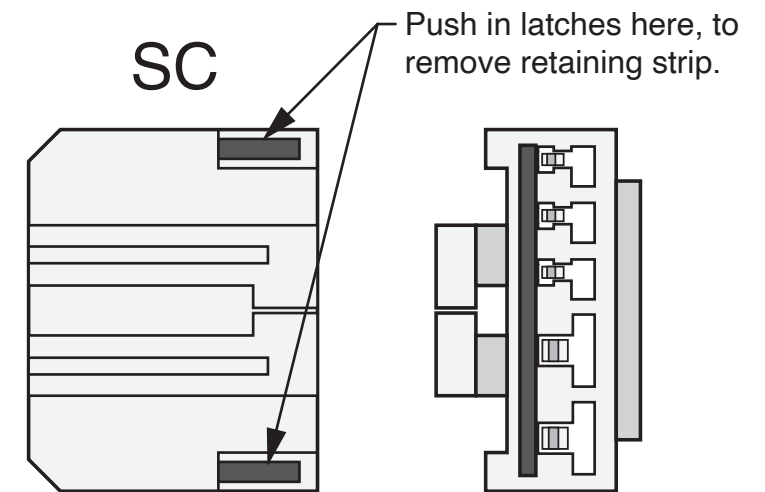

The two Wiper Motor connectors, have a retaining clip on the wire side, that must be removed, prior to pushing the latches to release the terminals. These retaining clips will be replaced, after the new terminals are installed. If the clips should break, during removal, the connectors will still work without them.

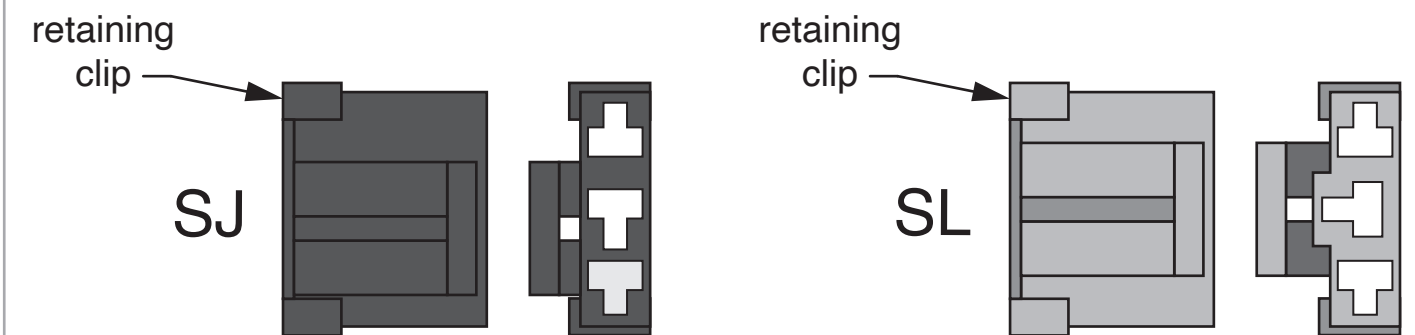

The terminals are not shown in these views, for clarity.

Dash/Main Harness installation instructions:

Shown below, are the connectors and grommets you will need to salvage/remove from your original Dash harness, that will be re-used (along with the supplied parts, on the following page) to complete your Dash/Main harness connections. They are itemized and referred to on this page, just as they are on the following pages of this Dash/Main instruction set (also see page 17, for parts salvaged from your original Rear Body harness). Terminal removal instructions, are on page 3. The original "donor" harnesses, for these salvaged parts, are in years 1987-93.

Salvaged AC Mode selector switch connector

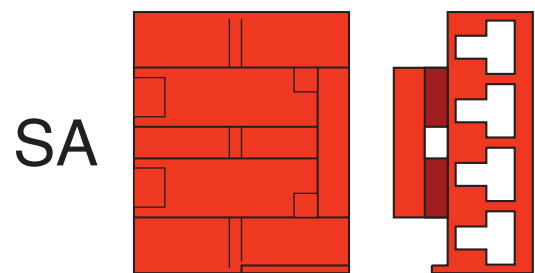

Salvaged Defrost Module (Black)

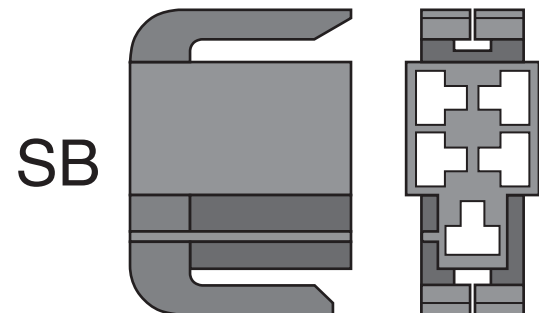

Salvaged Defrost Module (White)



Salvaged Defrost switch

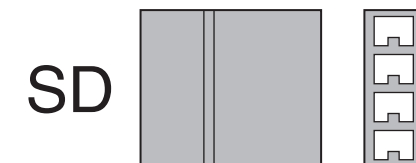

Salvaged Fog Lamp switch

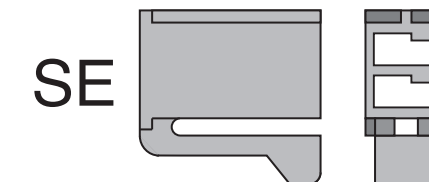

Salvaged Illumination Lamp connector



Salvaged Interior Dimmer

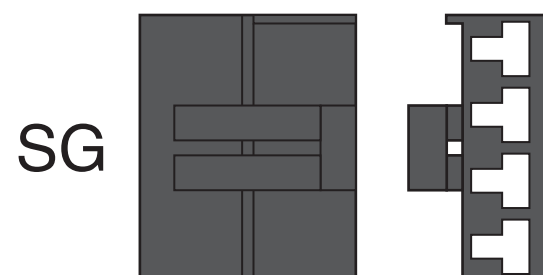

Salvaged Wiper Module
(cut existing wires, to length shown)

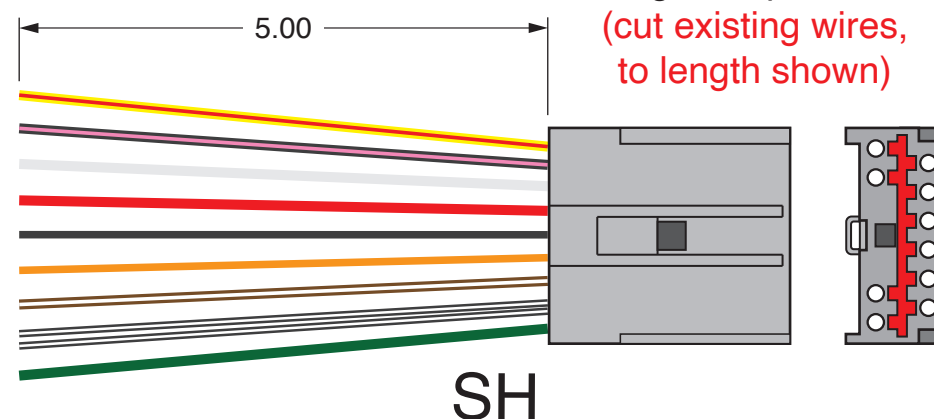

Salvaged Wiper Motor (Black)

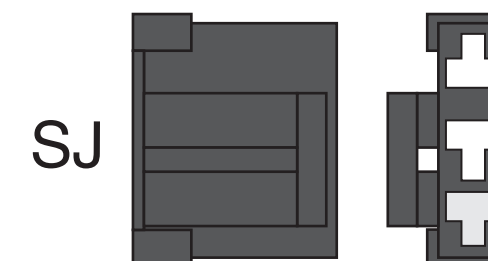

Salvaged Blower Motor

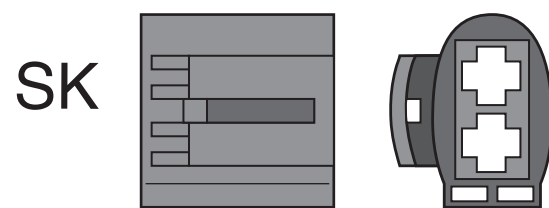

Salvaged Wiper Motor (Gray)

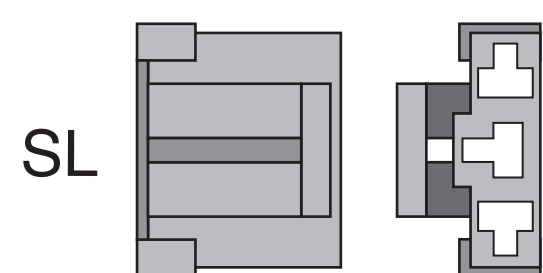

Salvaged Main firewall grommet

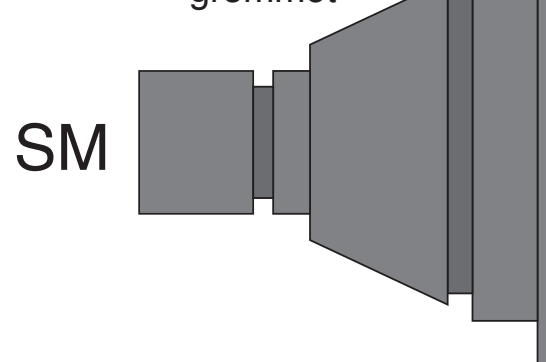

Salvaged ECU firewall grommet (if required)

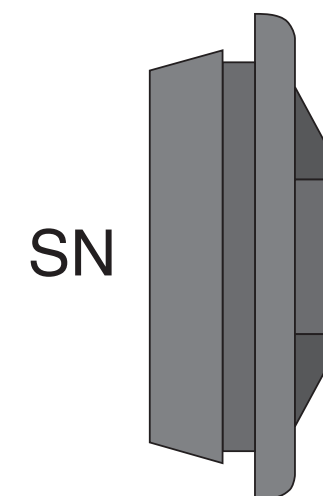









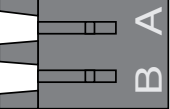

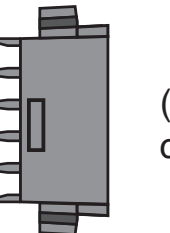
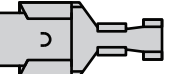
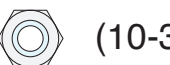

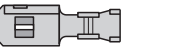
1987-89 Ford Mustang
Classic Update Series

510547 92970659 Rev 3.0 JDM 06/30/2023

Dash/Main Harness installation instructions:

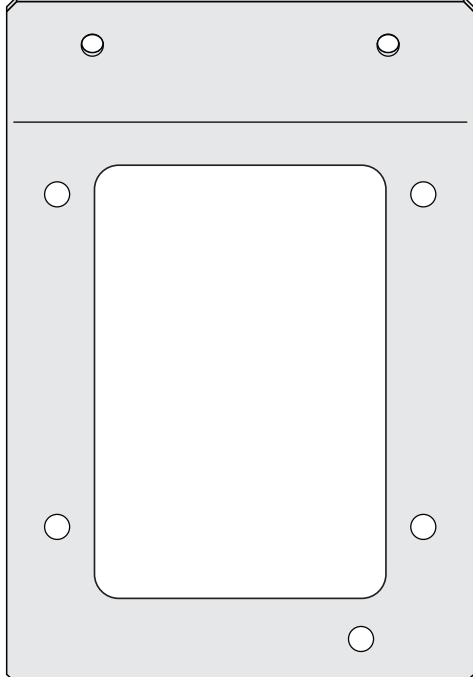
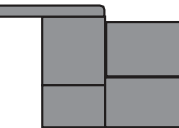
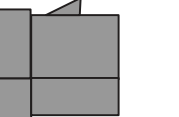
Shown below, are the supplied misc. terminals, plastic connector bodies, hardware, and bracket, that will be used (along with the salvaged parts that were removed from your original Dash harness, from the previous page) to complete your Dash/Main harness connections. They are itemized and referred to on this page, just as they are on the following pages of this Dash/Main instruction set.

- A  (Pack-con 2-way male conn, 1 pc.)
- B  (male flat Pack-con terminal, 11 pcs.)
- C  (Pack-con 9-way male conn, 1 pc.)
- D  (56 series single female terminal, 7 pcs.)
- E  (10-32 nut, 1 pc.)
- F  (10-32 screw, 5 pcs.)
- G  (large box terminal, 5 pcs.)
- H  (small box terminal, 3 pcs.)
- J  (56 series 2-way female conn, 2 pcs.)
- K  (single female terminal, 3 pcs.)
- L  (single male terminal, 3 pcs.)
- M  (sleeve, 6 pcs.)
- N  (Fuse box mounting bracket, 1 pc.)
- P  (56 series 3-way male conn, 2 pcs.)
- R  (56 series 3-way female conn, 1 pc.)
- T  (56 series single male terminal, 3 pc.)

PLEASE READ THIS HELPFUL INSTALLATION TIP, BEFORE GOING ANY FURTHER!

Prior to installing the Dash/Main harness in your dashboard, plug all of the fuses and circuit breakers (see detailed picture below), Horn Relay, Hazard Flasher and Turn Flasher (see detailed picture below), into this harness.

Trim leads of both circuit breakers, where shown, prior to installing in fuse box.

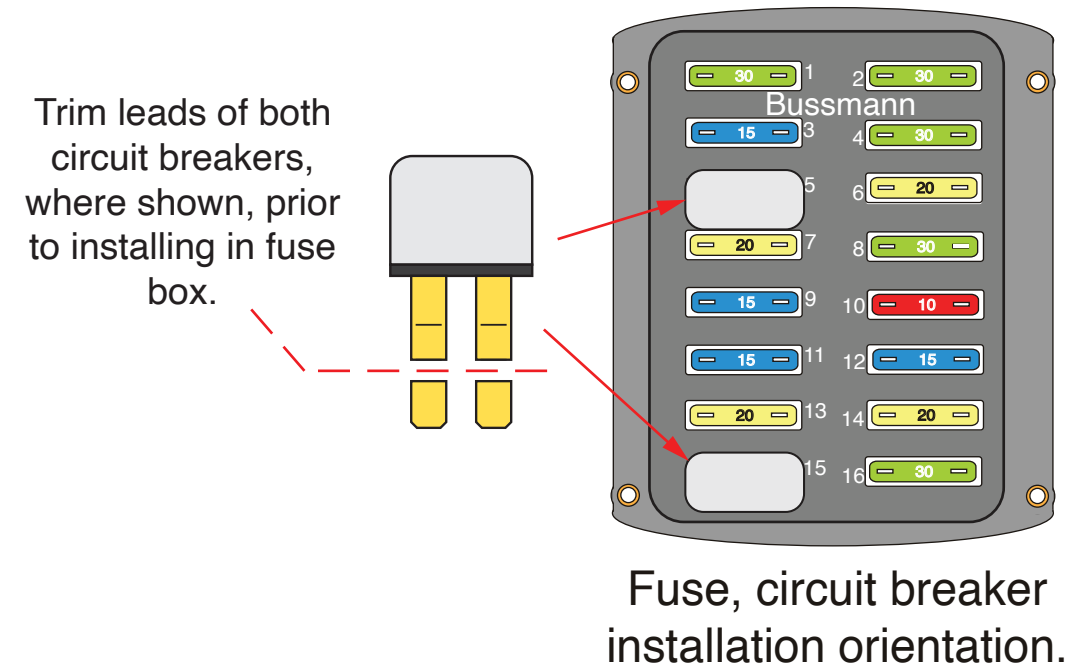

Rear Defrost 30A - BAT	1	Fuel Pump 30A - BAT	2
Dome Light 15A - BAT	3	Brake Light 30A - BAT	4
Pwr Locks CB - BAT	5	Clock/Cigar 20A - BAT	6
Hazard 20A - BAT	7	Headlights 30A - BAT	8
Turn Signal 15A - IGN	9	Fuel Relay 10A - IGN	10
Back Up Lts 15A - IGN	11	Gauges 15A - IGN	12
Wiper 20A - ACC	13	Radio 20A - ACC	14
Pwr Window CB - ACC	15	Heat / AC 30A - ACC	16

Fuse label shown on inside of fuse box cover; may be placed anywhere.

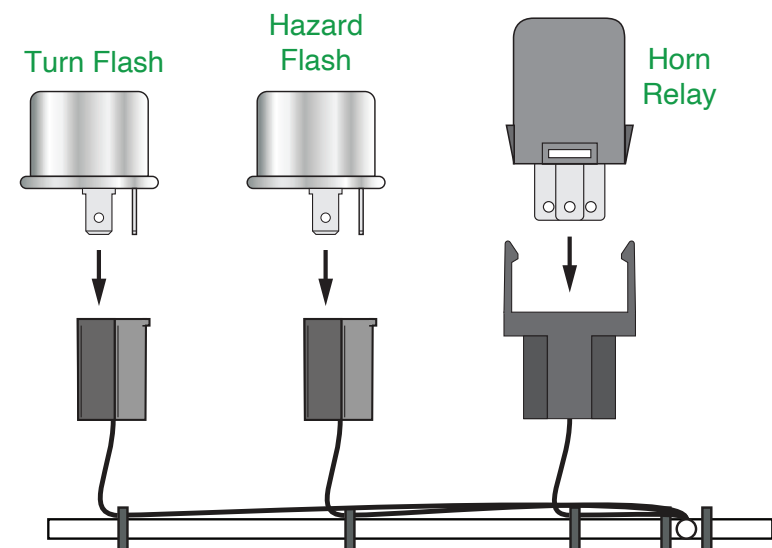

1987-89 Ford Mustang
Classic Update Series

510547 92970659 Rev 3.0 JDM 06/30/2023



Dash/Main Harness installation instructions:

It is recommended that the connector terminations and harness installations, on the following pages, are performed in the order they are presented.

The connectors on this page, should have their wires installed, on a bench or work area, prior to installing the harness, in the dashboard.

The indexing shown for each connector is from the face-view, not the wire-entry perspective.

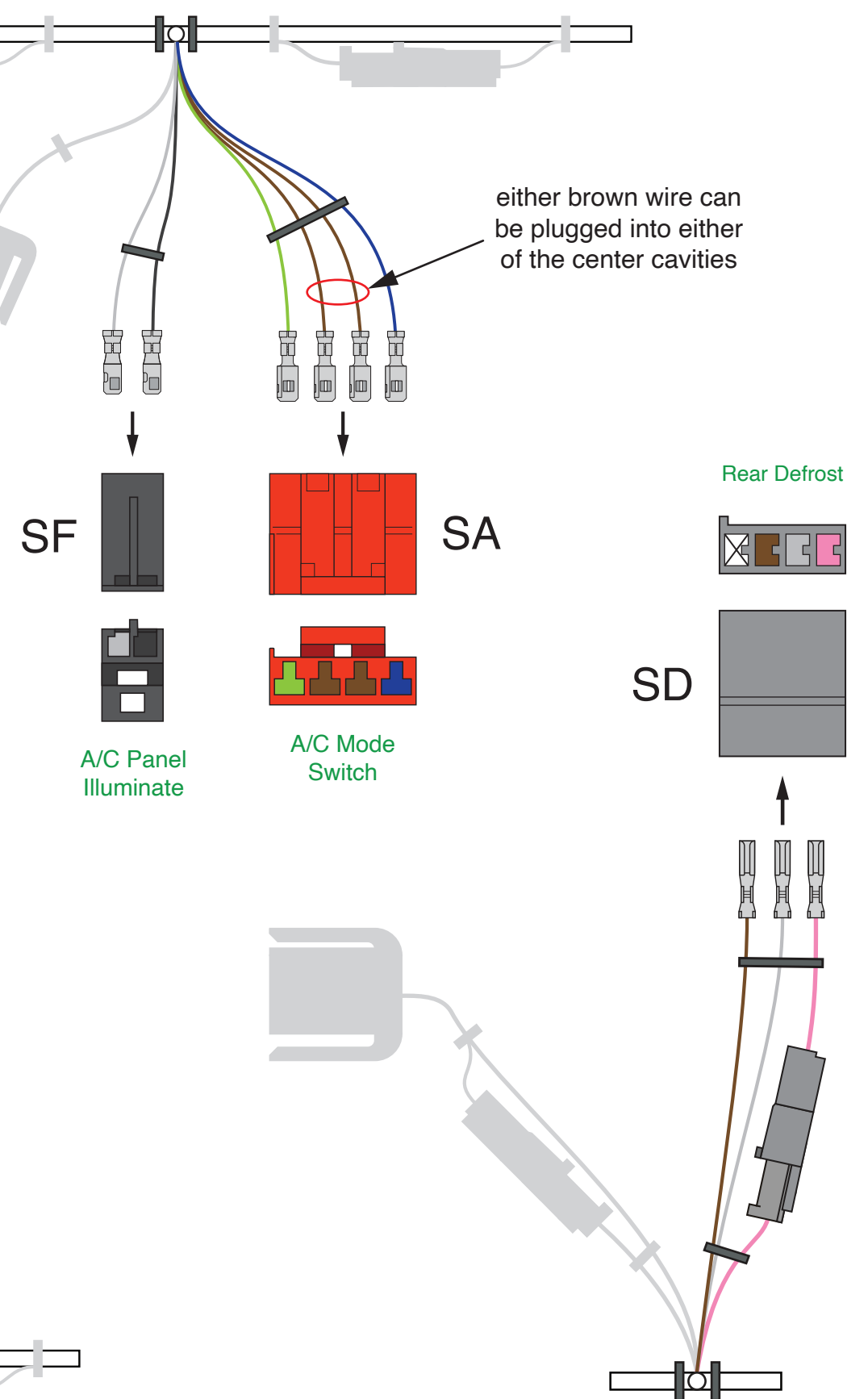
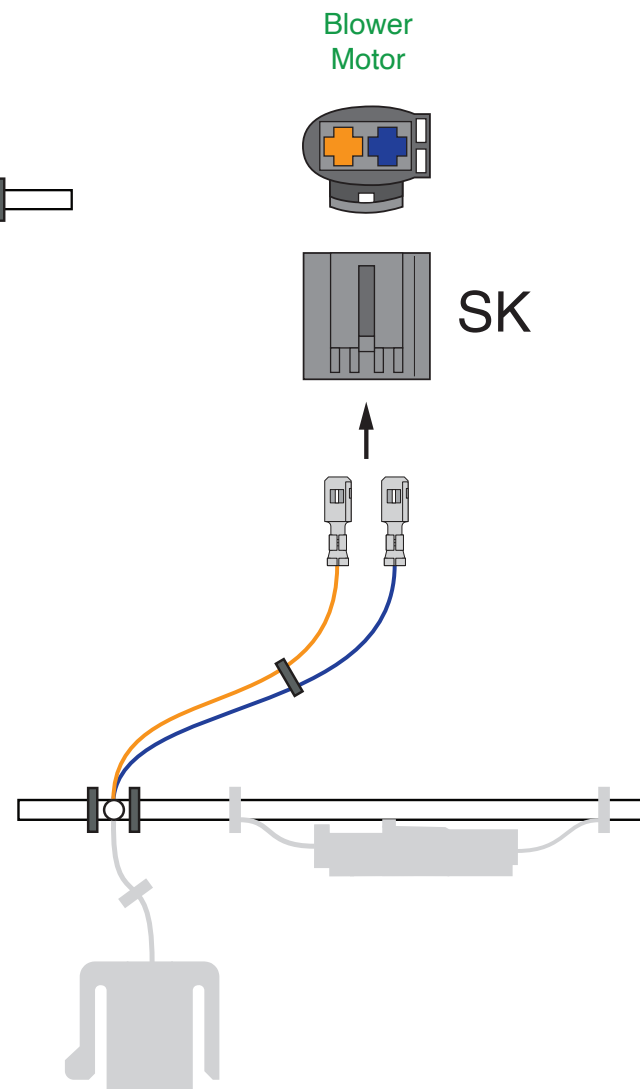
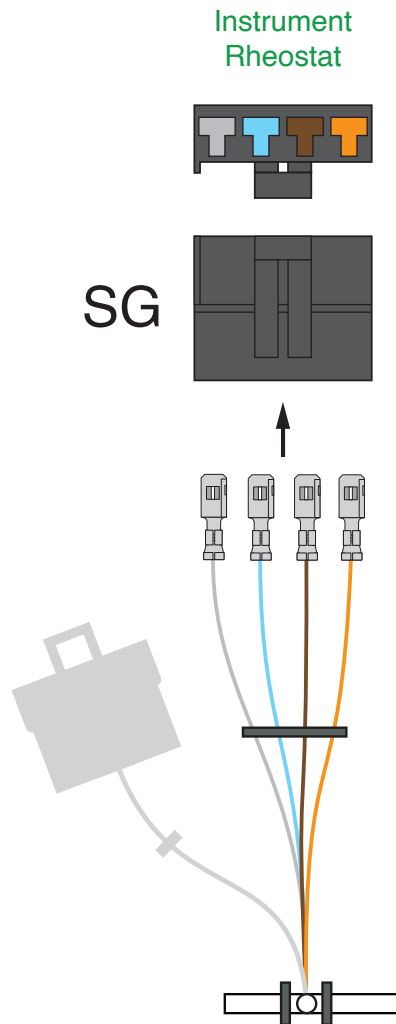
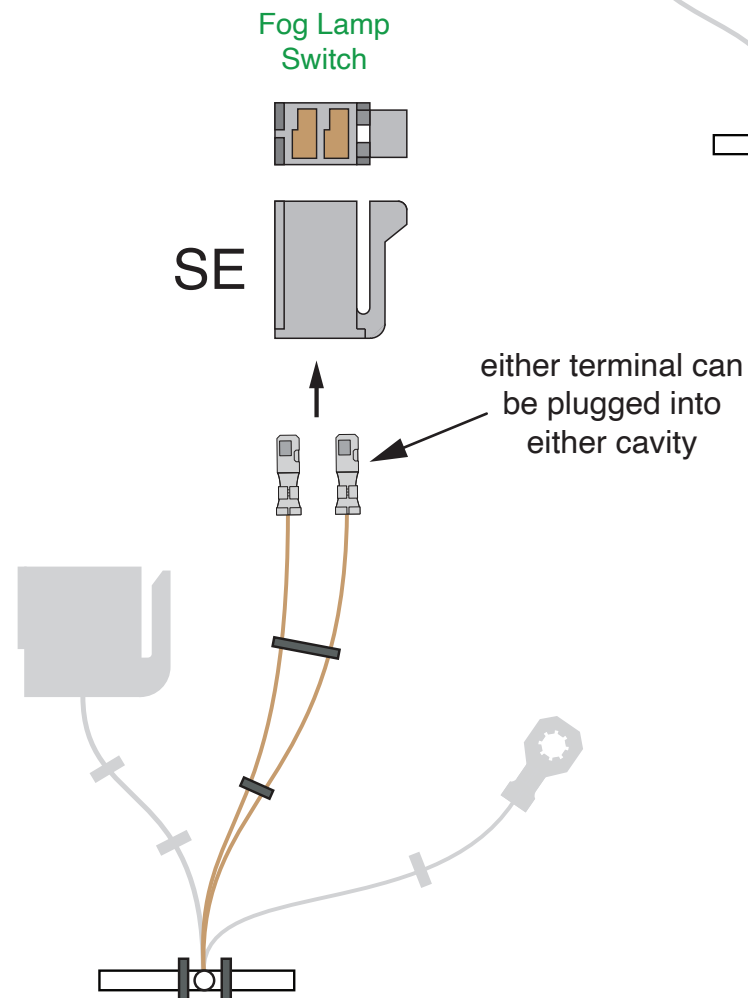
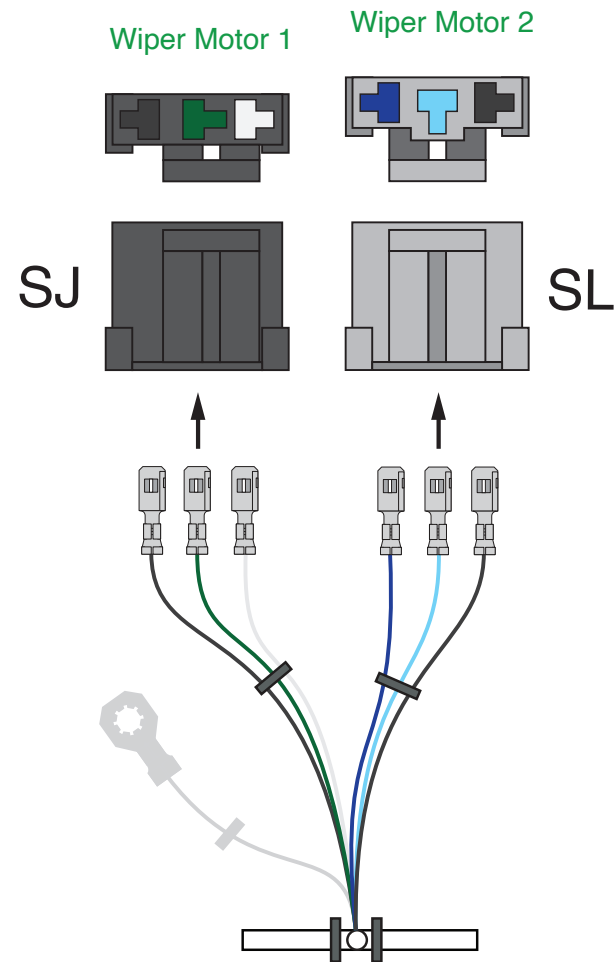

**American
Autowire**

Dash/Main Harness installation instructions:

The terminals and connectors on this page, should be installed on a bench or work area, prior to installing the harness in the dashboard.

The indexing shown for each connector is from the face-view, not the wire-entry perspective.

WARNING:

Do not remove the Power Windows/Locks/Mirrors harness, that runs along the top of the firewall, behind the dashboard, if you plan on using Power Windows/Locks/Mirrors.

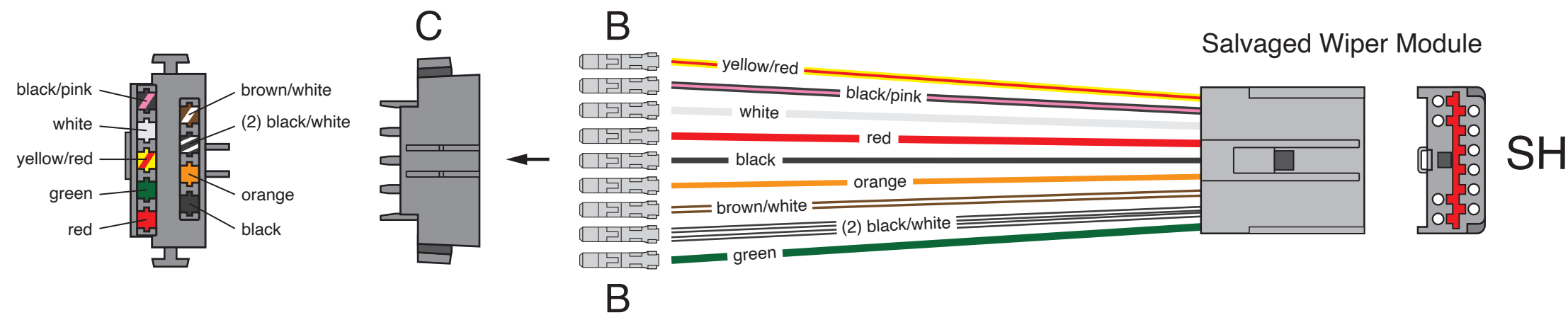
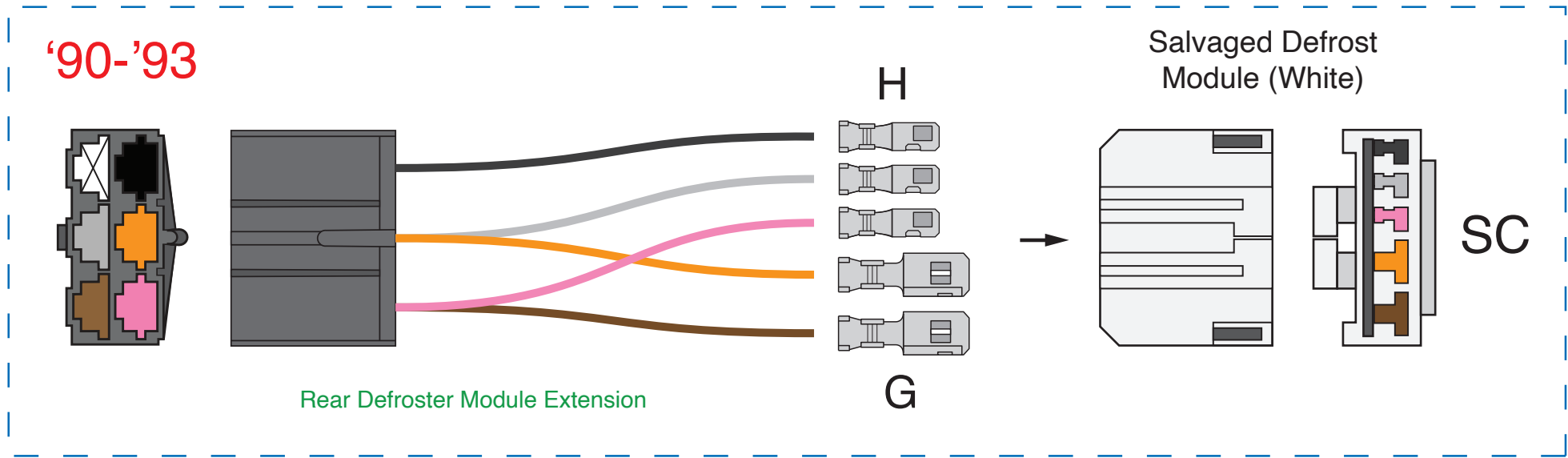
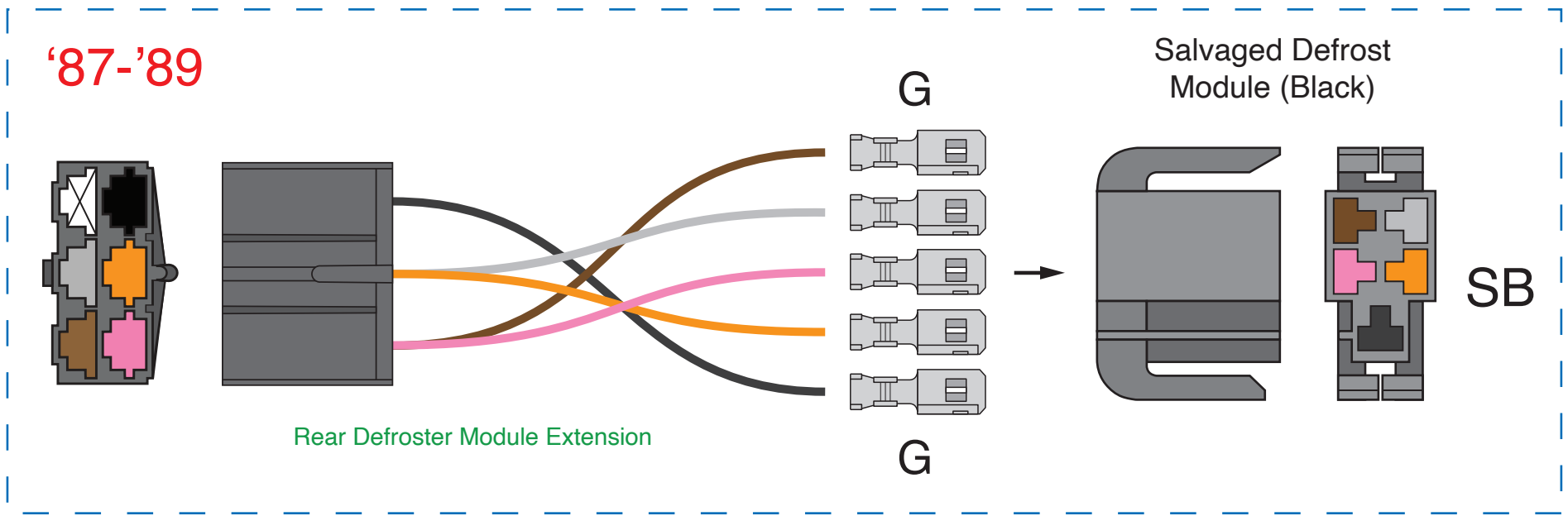

www.americanautowire.com 856-933-0801

1987-89 Ford Mustang

Classic Update Series

510547 92970659 Rev 3.0 JDM 06/30/2023

Dash/Main Harness installation instructions:

Rear of Dashboard

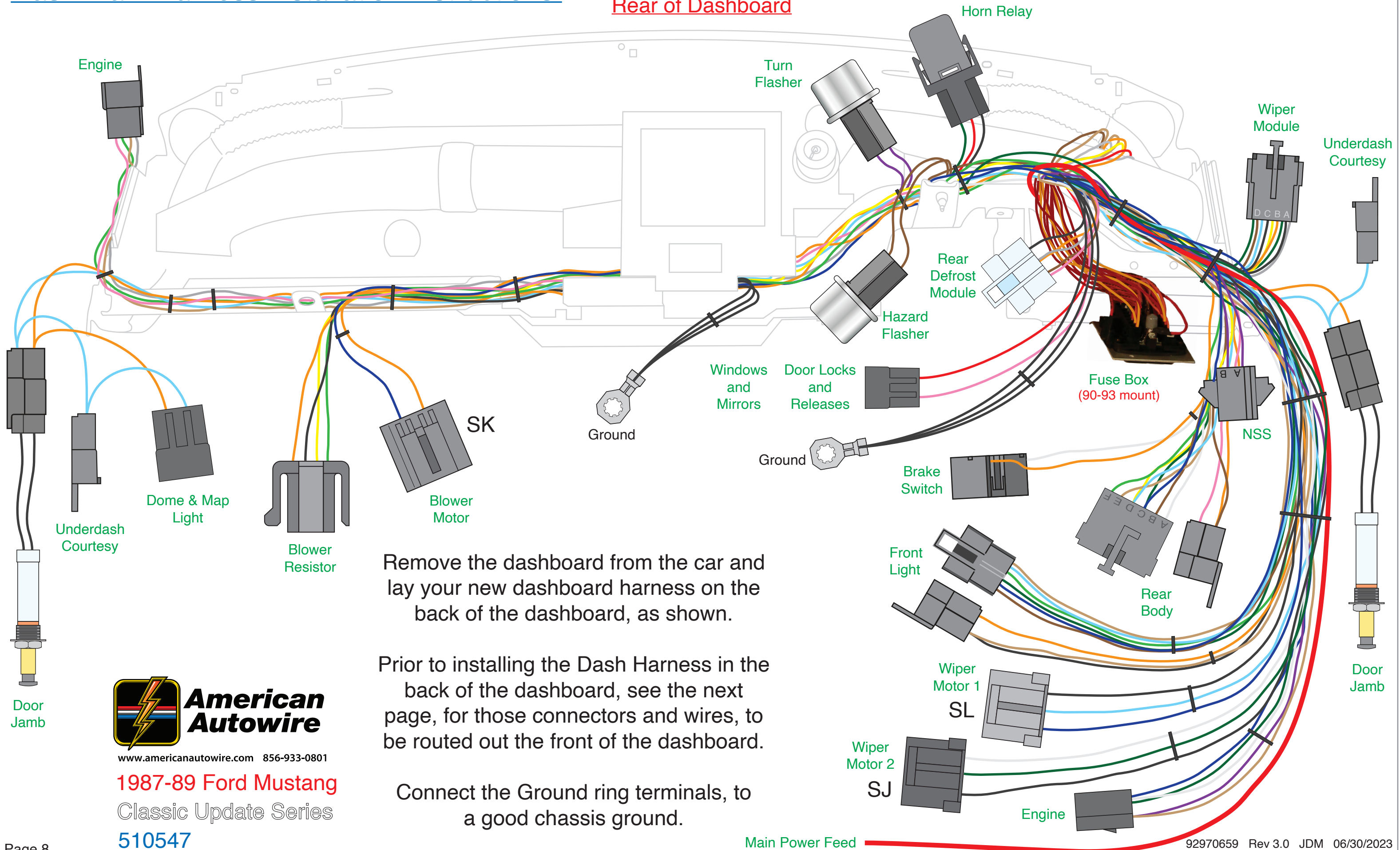

Remove the dashboard from the car and lay your new dashboard harness on the back of the dashboard, as shown.

Prior to installing the Dash Harness in the back of the dashboard, see the next page, for those connectors and wires, to be routed out the front of the dashboard.

Connect the Ground ring terminals, to a good chassis ground.



www.americanautowire.com 856-933-0801

1987-89 Ford Mustang
Classic Update Series
510547

Dash/Main Harness installation instructions:

Front of Dashboard (instrument panel removed)

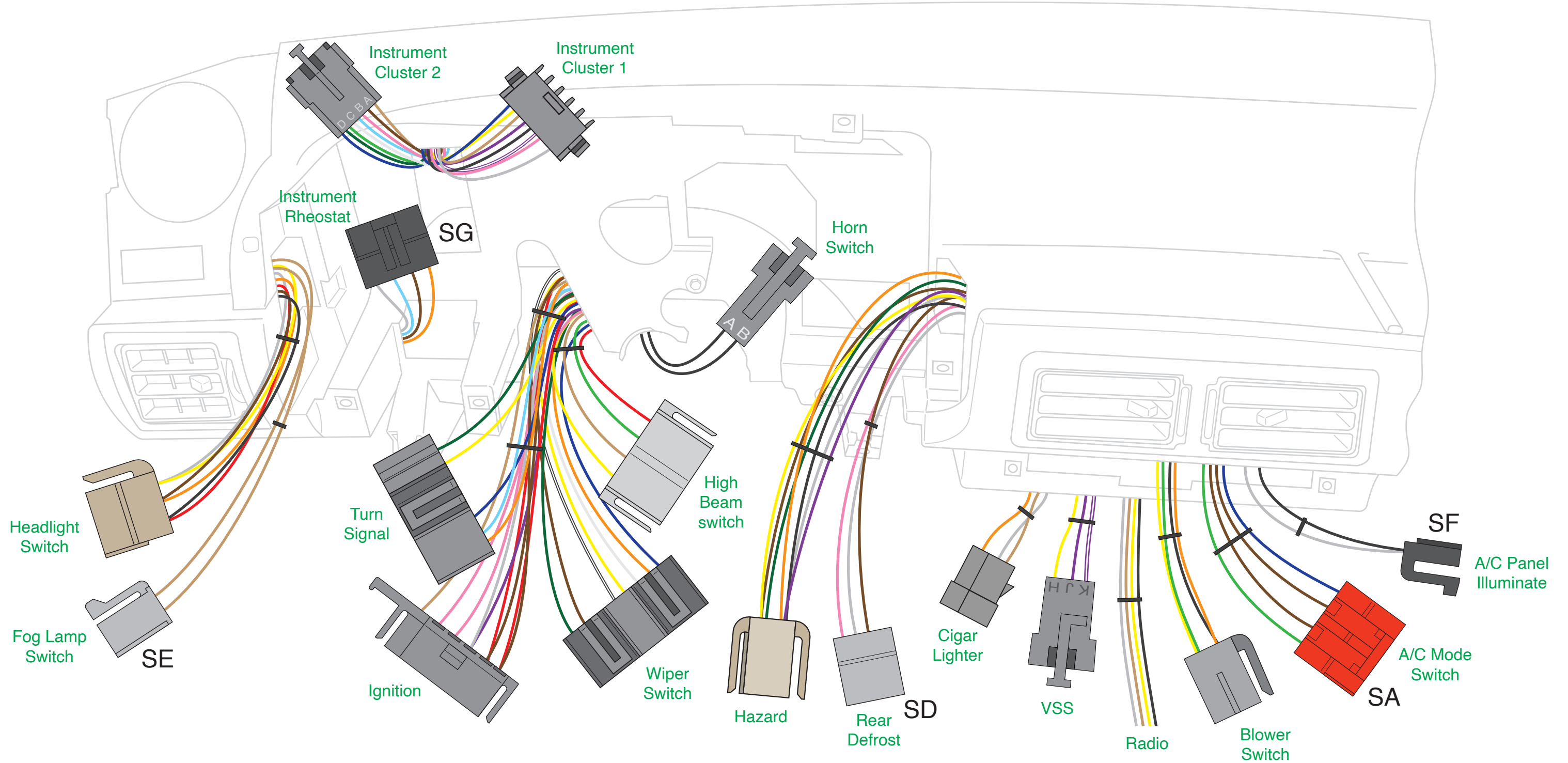

While installing the Dash Harness in the back of the dashboard, route these connectors and wires out the front of the dashboard, as shown.



Dash/Main Harness installation instructions:

1987-89 Fuse Box installation:

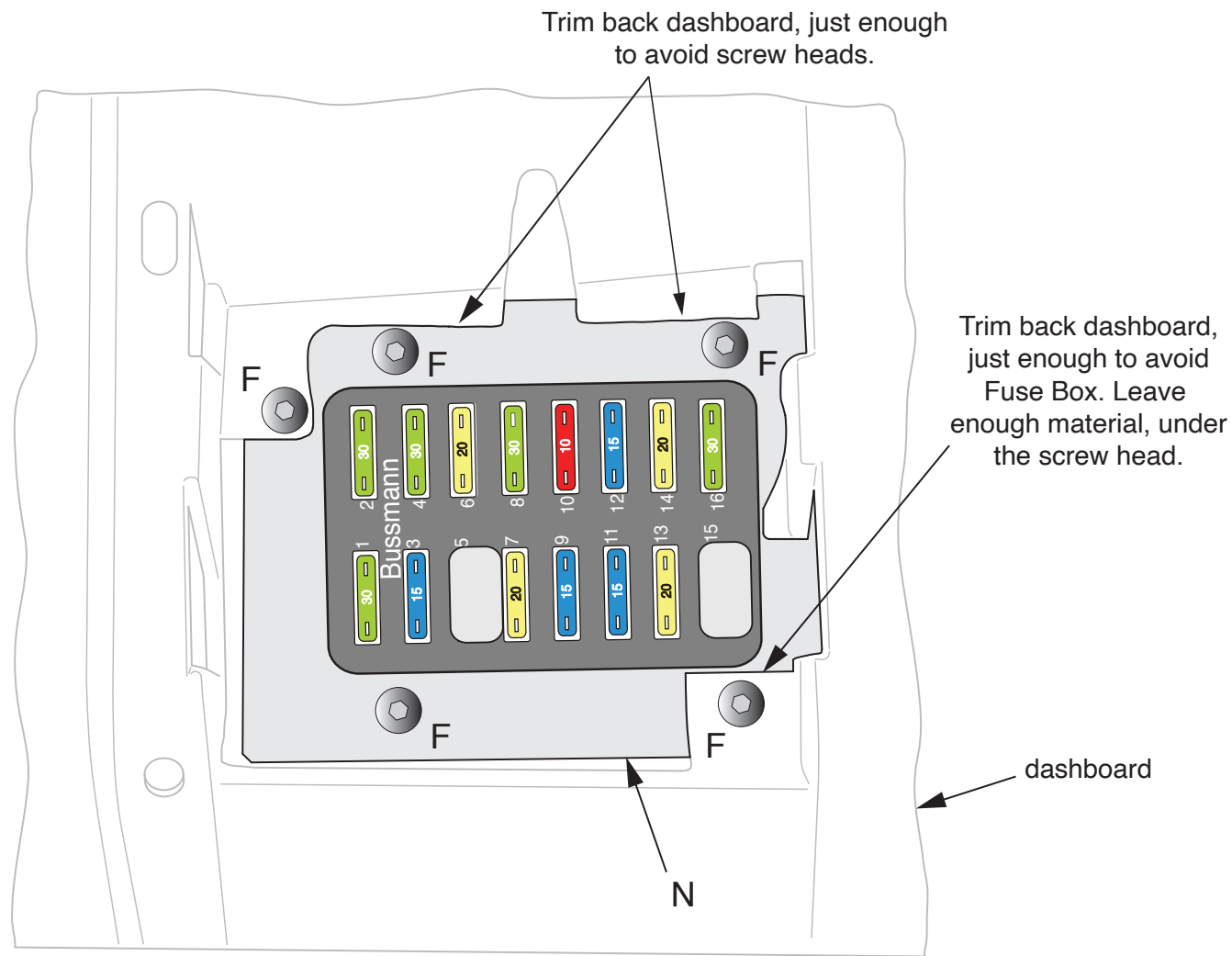

Front of dashboard, with Fuse Box access panel removed.

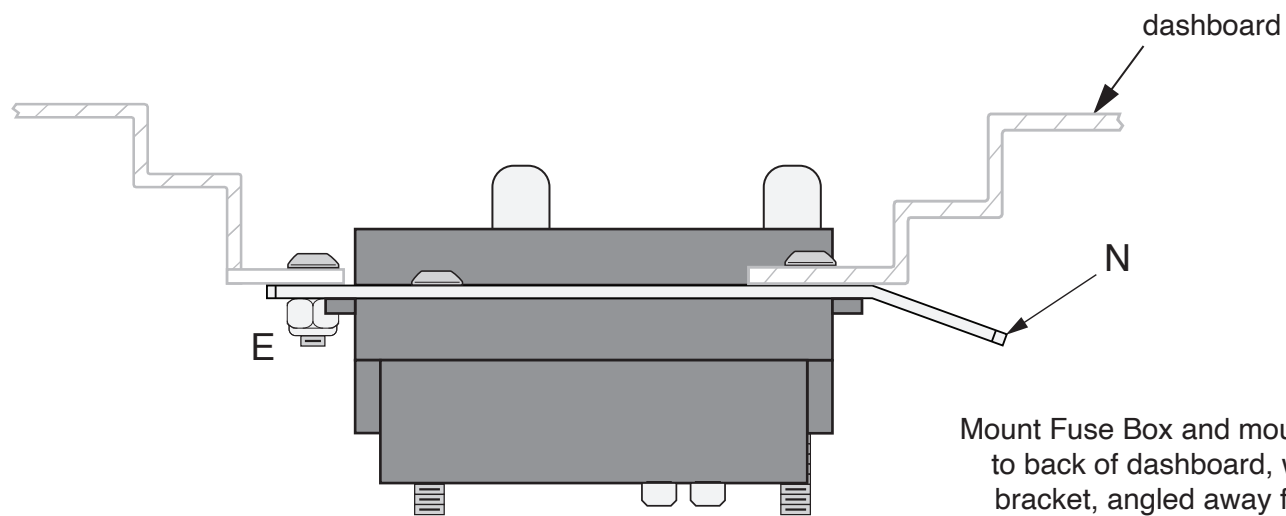

Looking up, at bottom edge of dashboard, with Fuse Box access panel removed.

Mount Fuse Box and mounting bracket "N", to back of dashboard, with bent end of bracket, angled away from dashboard (remainder of Dash Harness, is not shown in this view).

1990-93 Fuse Box installation:

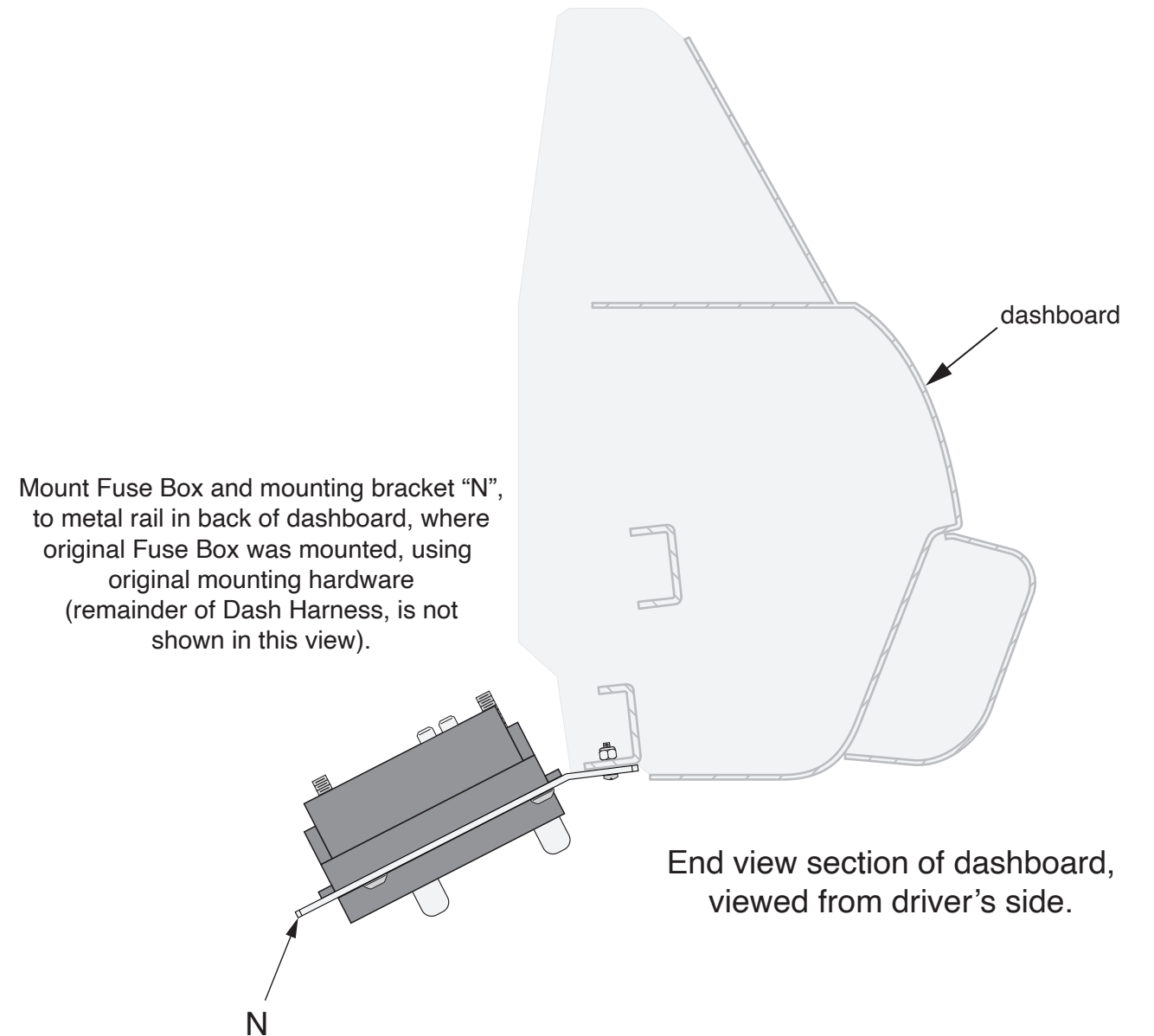

End view section of dashboard, viewed from driver's side.



www.americanautowire.com 856-933-0801

1987-89 Ford Mustang

Classic Update Series

510547 92970659 Rev 3.0 JDM 06/30/2023

Dash/Main Harness installation instructions:

Plug these connectors into their mating connectors, found at the steering column. See the note at the Wiper Switch connector, for '90-'93 models. Cut the original terminals, from the original Horn wires and terminate the wires as shown.

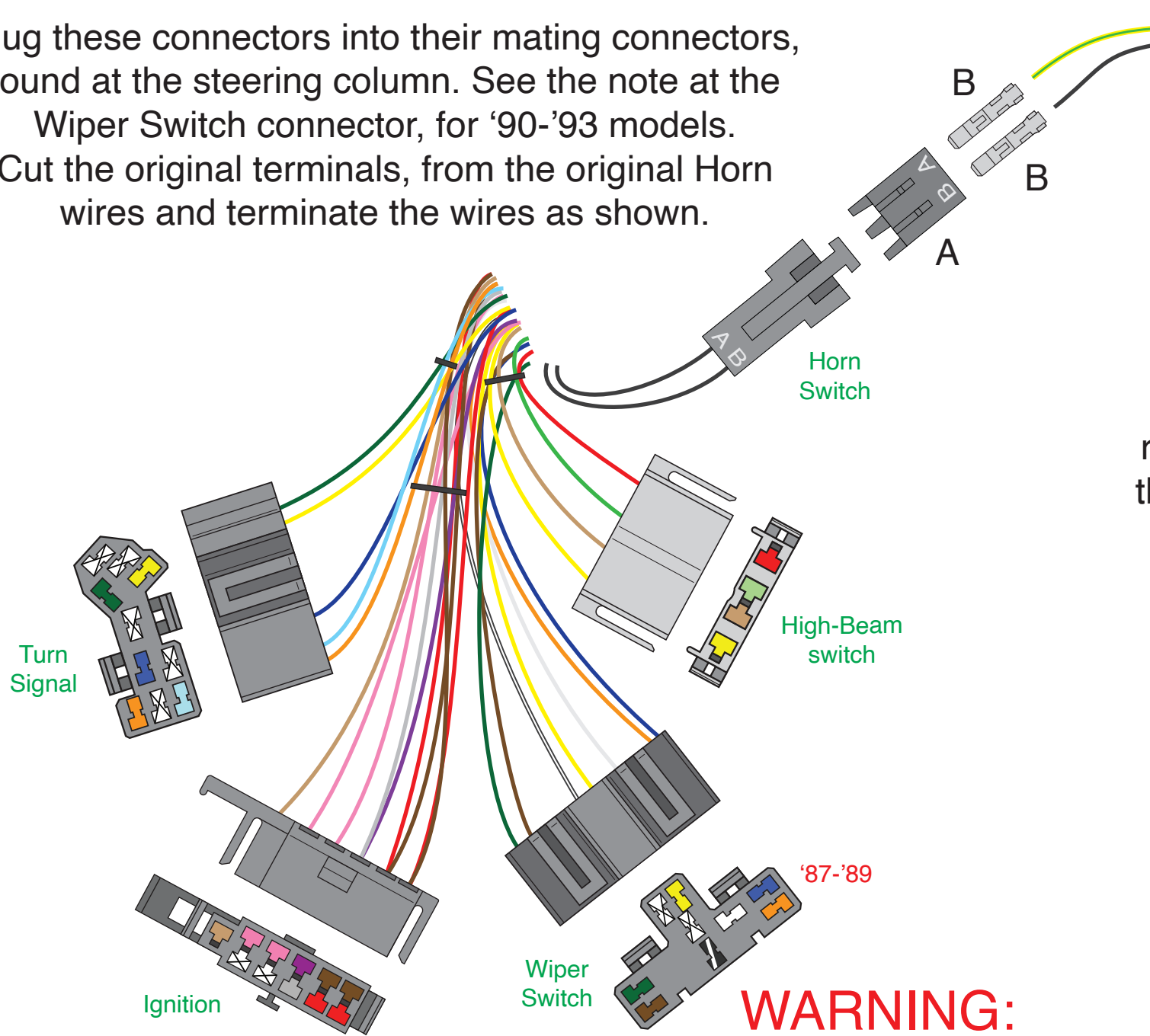

WARNING:

The Wiper Switch connector, comes wired for '87-'89 models, as shown above. For '90-'93 models, remove the orange, white and black/white wires and re-insert them, as shown below.

'87-'89

'90-'93

Plug these connectors into their mating connectors, found on the blower plenum, under the dash.

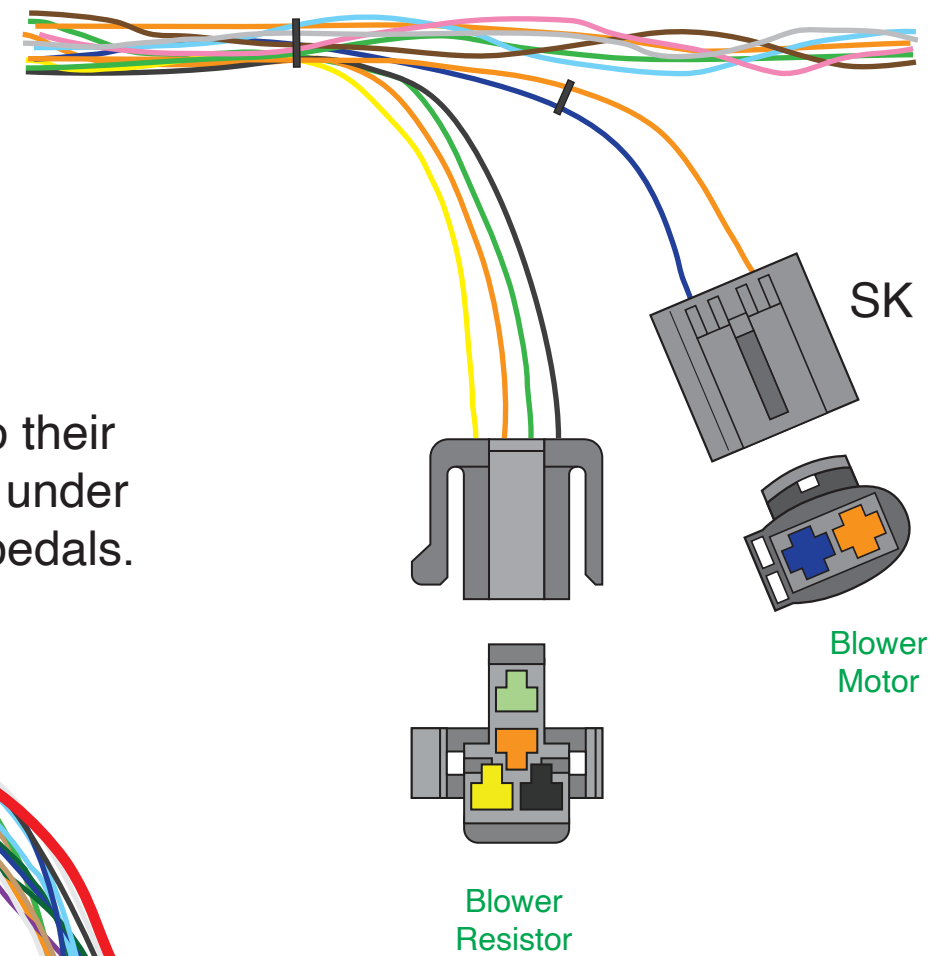

Plug these connectors into their respective switches, found under the dashboard, above the pedals.

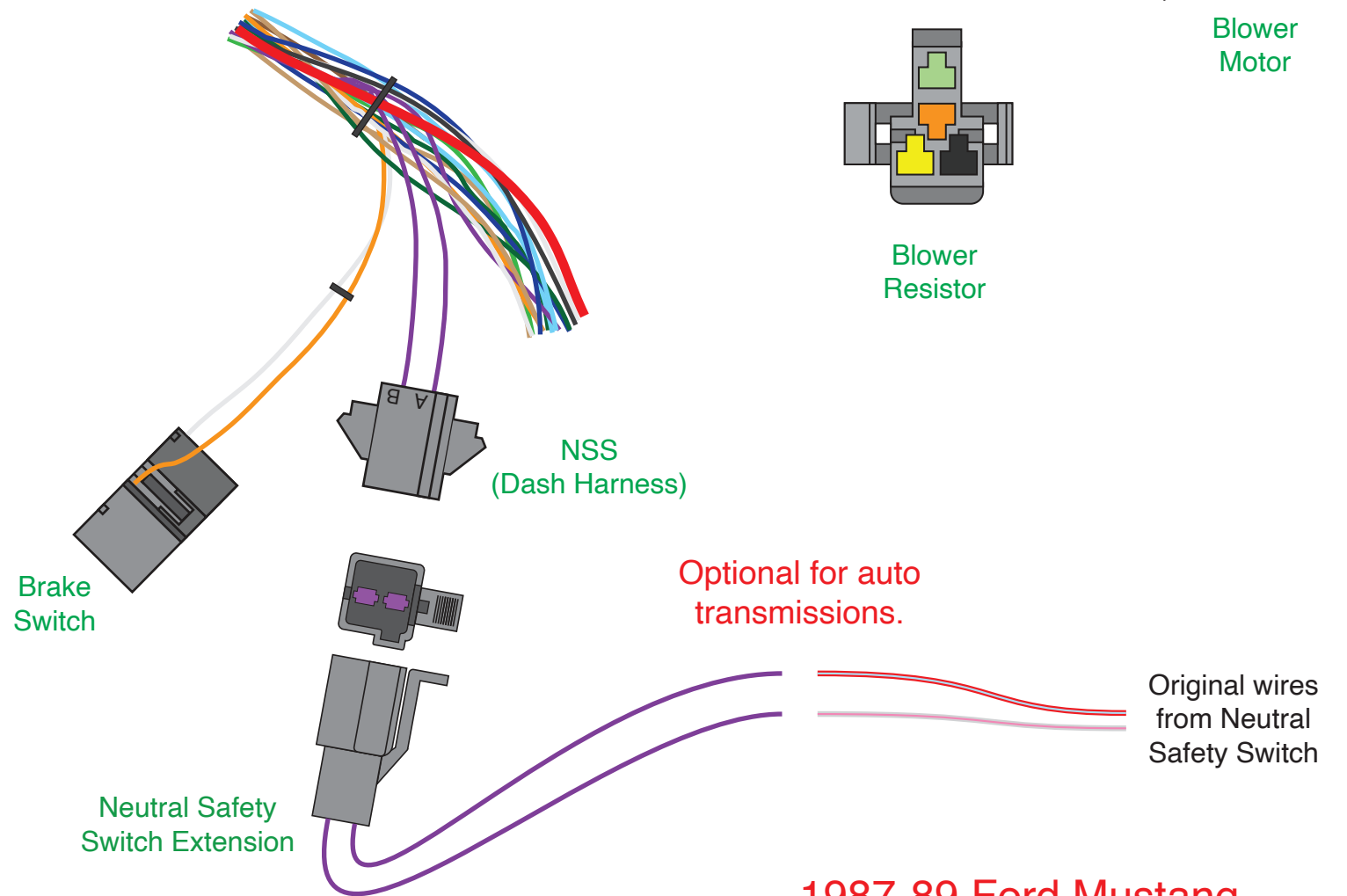

Dash/Main Harness installation instructions:

Plug the wiper connectors into the wiper motor.

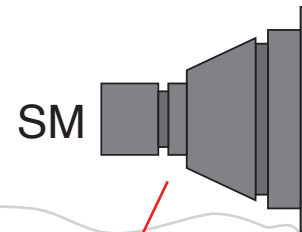

Route the Engine, Front Light, Wiper, Ground and the red Main Power Feed wires, through the driver side of the firewall, using the large circular grommet (SM) salvaged from the original dash harness. Make sure the Ground is connected to a good chassis ground.

The Engine, Front Light, and red Main Power Feed can be routed in the engine compartment or in the inner fender to hide the wires.

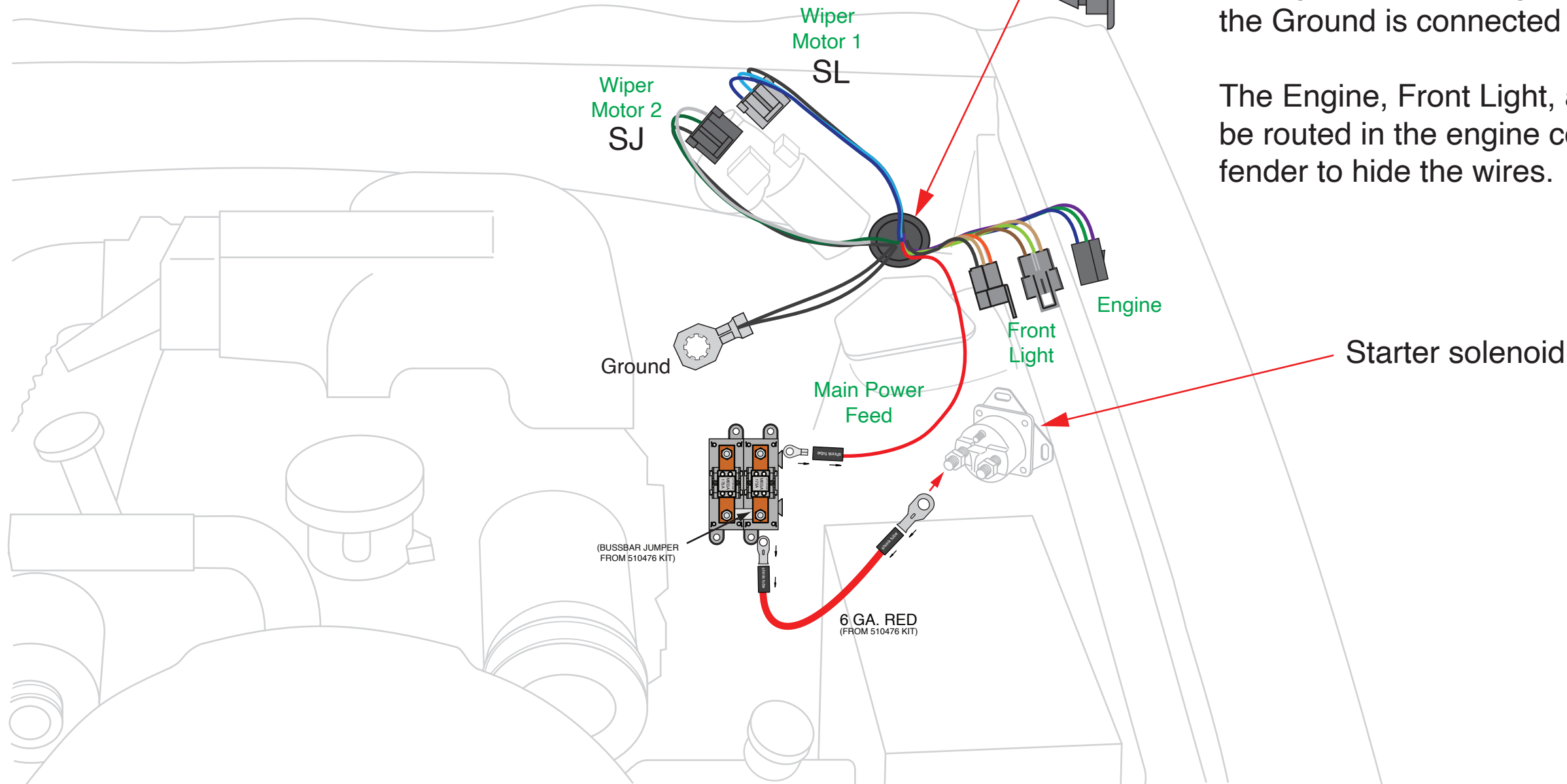

Mount the Mega Fuses (510476) included with this kit in a location close to the starter solenoid. Route red main power feed to the Mega Fuse. Cut to length and install ring terminal per the instructions included with the 510476 kit. Use a section of the 6ga wire to connect the Mega Fuse to the battery side of the starter solenoid, using the ring terminals supplied with the 510476 kit.



Dash/Main Harness installation instructions:

Use radio manufacturer's instructions to connect your radio.
The functions of the wire's provided in the dash harness are:

- Gray - Dash Lights
- Yellow - 12v battery feed for Clock or memory
- Tan - 12v accessory feed for main radio power
- Black - Ground

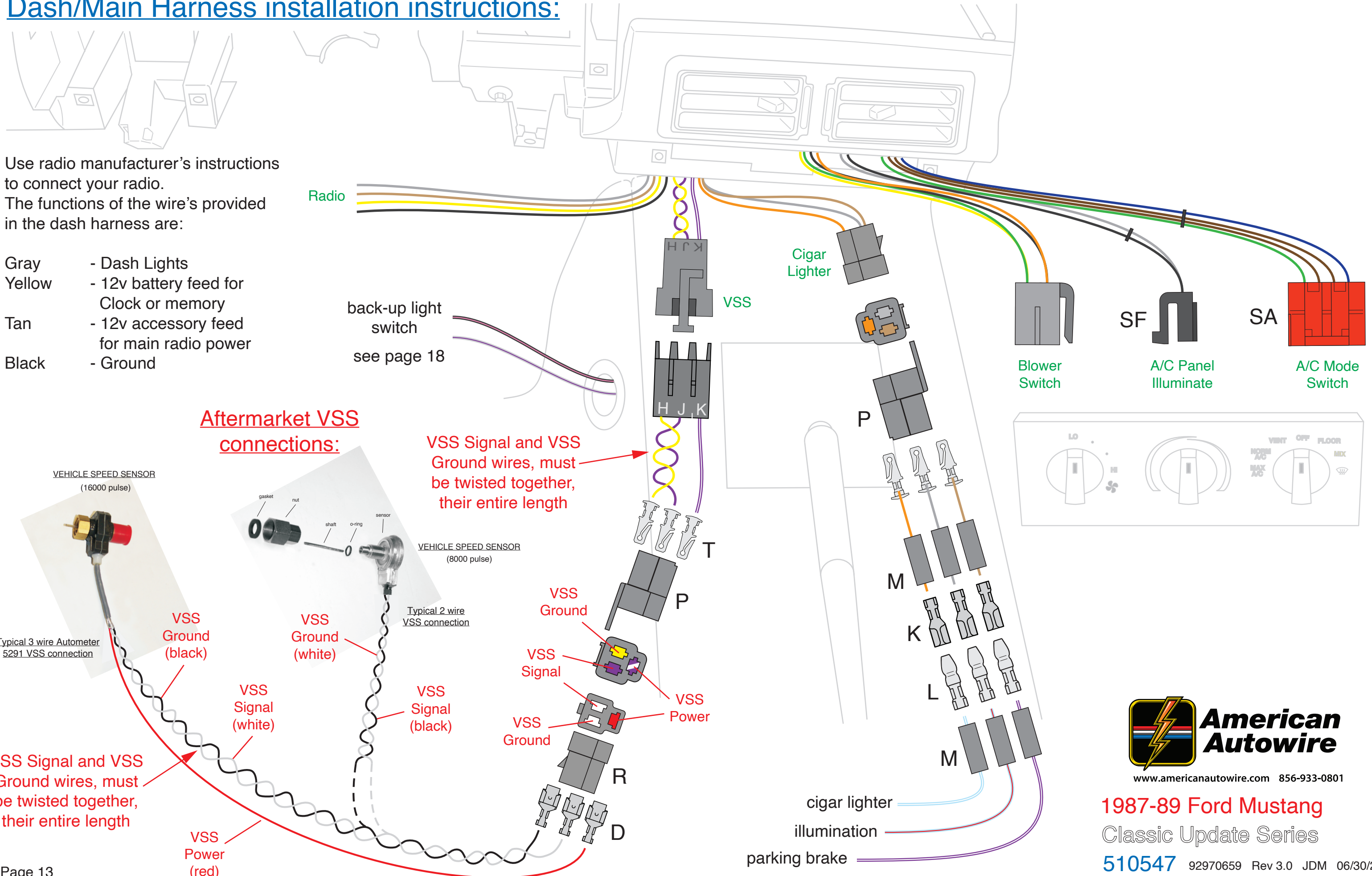

Aftermarket VSS connections:

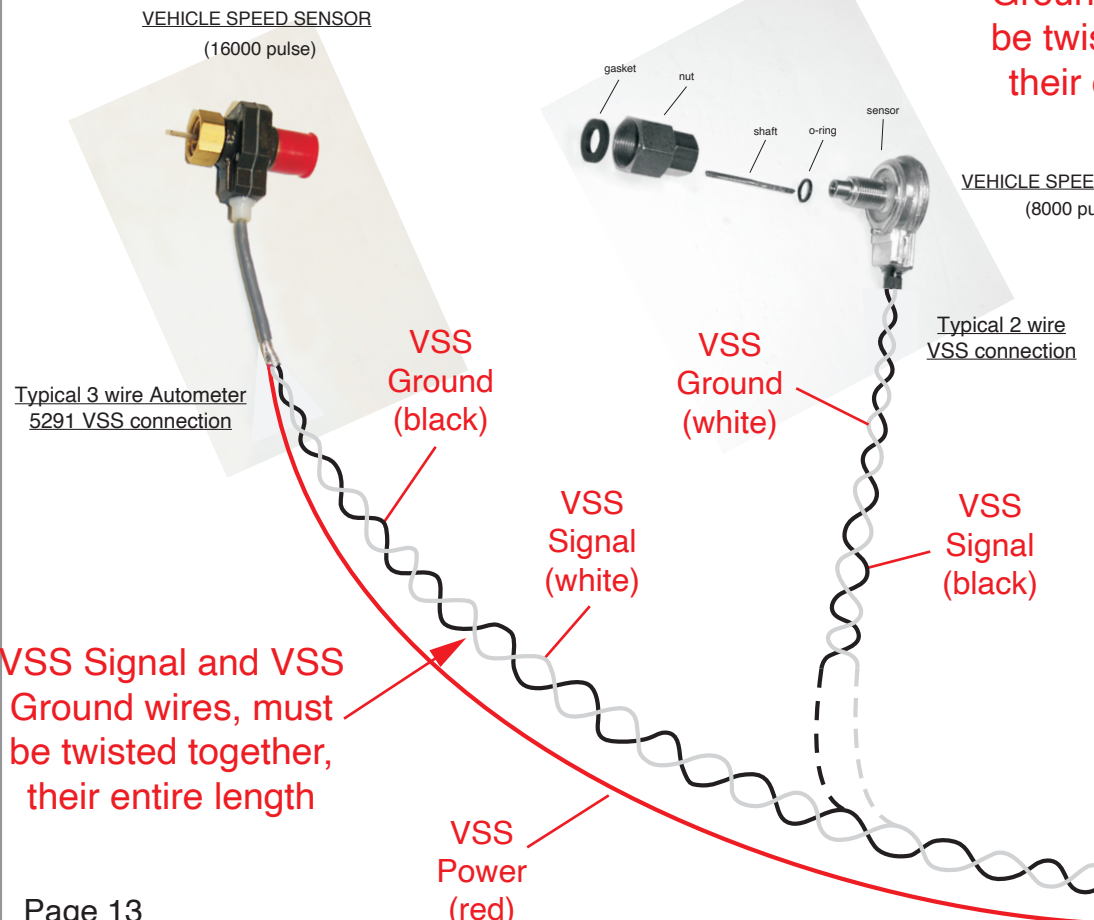

VSS Signal and VSS Ground wires, must be twisted together, their entire length

VSS Signal and VSS Ground wires, must be twisted together, their entire length



www.americanautowire.com 856-933-0801

1987-89 Ford Mustang
Classic Update Series

510547 92970659 Rev 3.0 JDM 06/30/2023

Dash/Main Harness installation instructions:

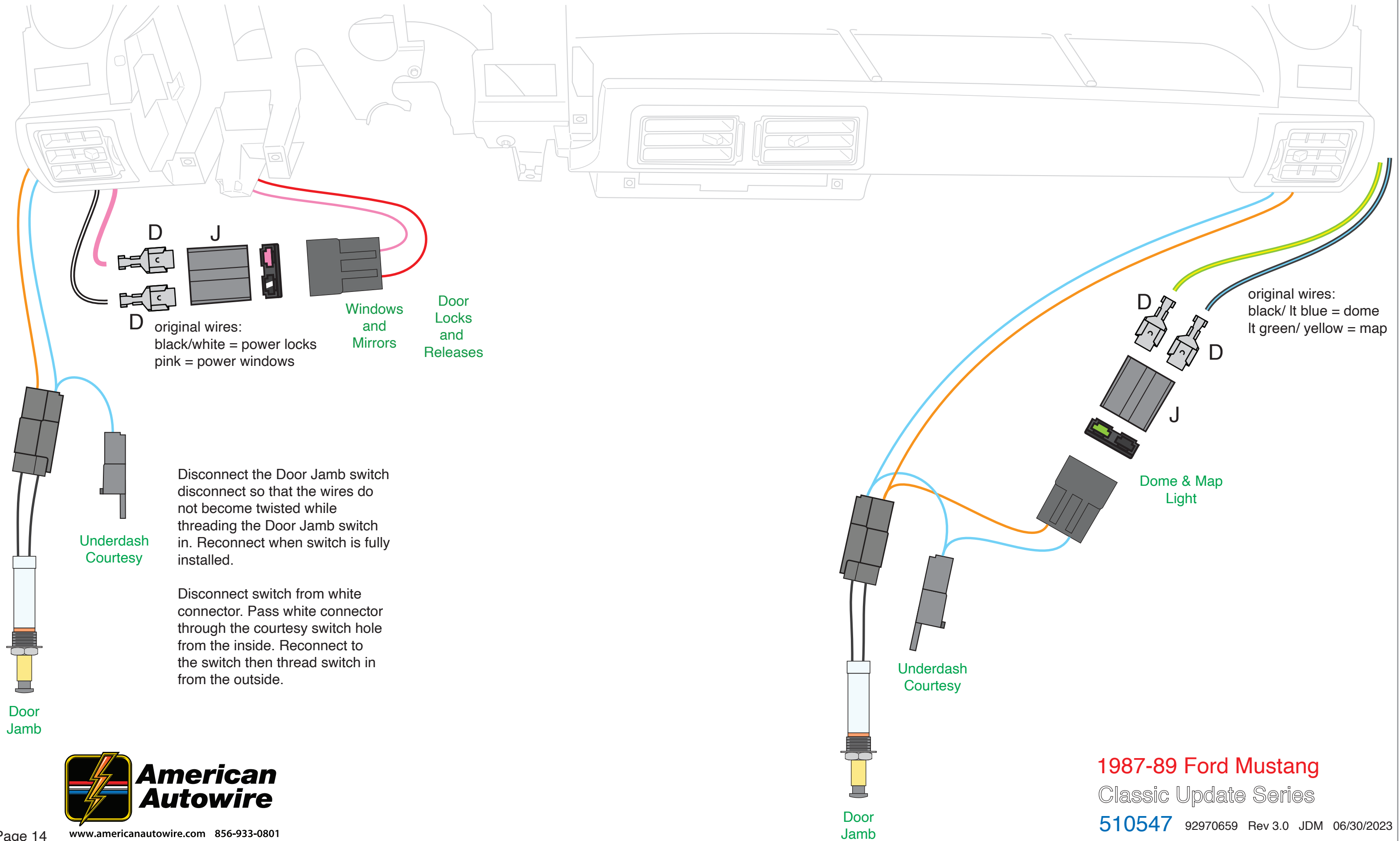

Gauge Cluster Harness (aftermarket gauges) installation instructions:

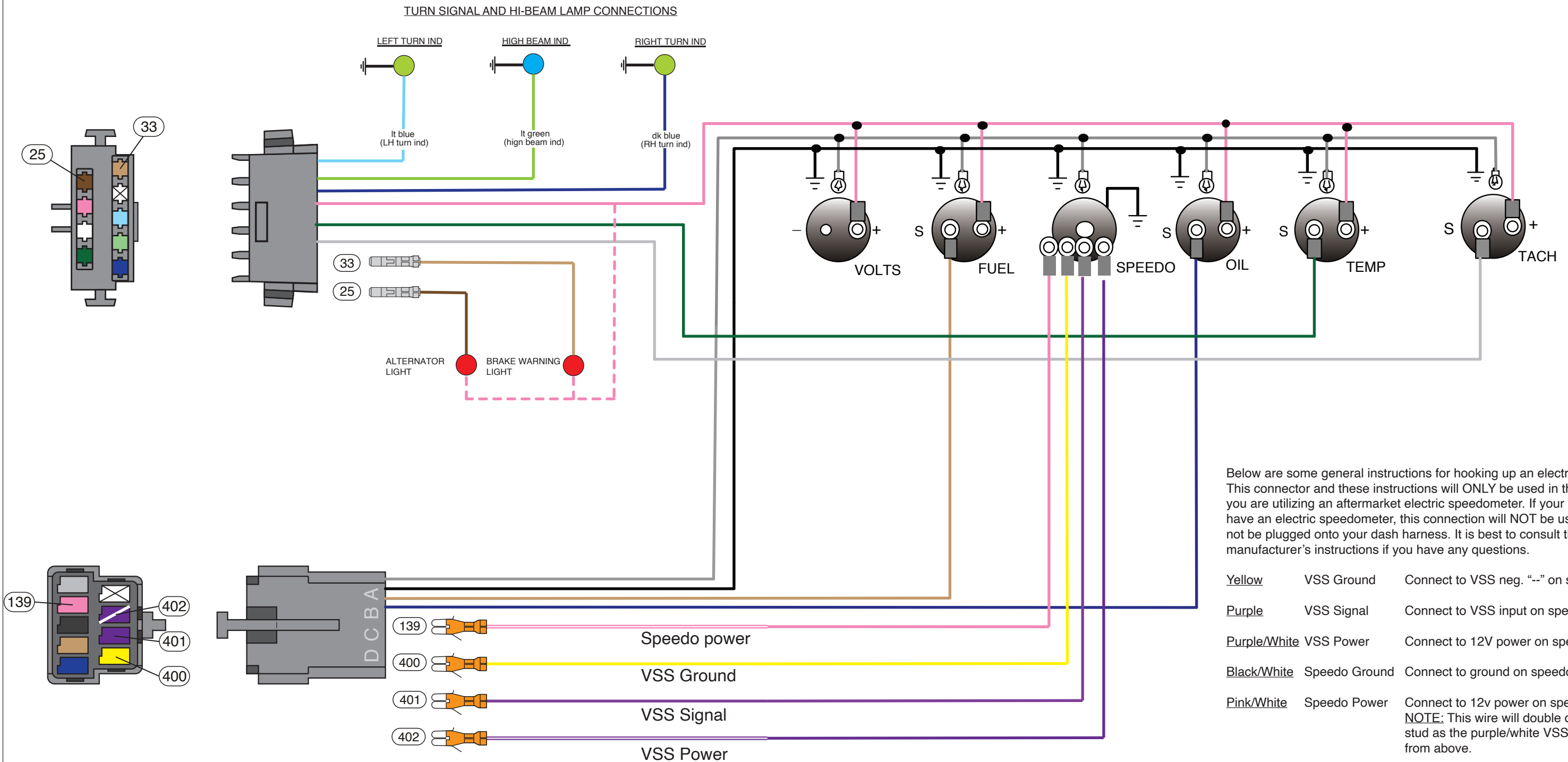

Below are some general instructions for hooking up an electric speedometer. This connector and these instructions will ONLY be used in the event that you are utilizing an aftermarket electric speedometer. If your car does NOT have an electric speedometer, this connection will NOT be used and should not be plugged onto your dash harness. It is best to consult the speedometer manufacturer's instructions if you have any questions.

See page 16.



Gauge Cluster Harness (aftermarket gauges) installation instructions:

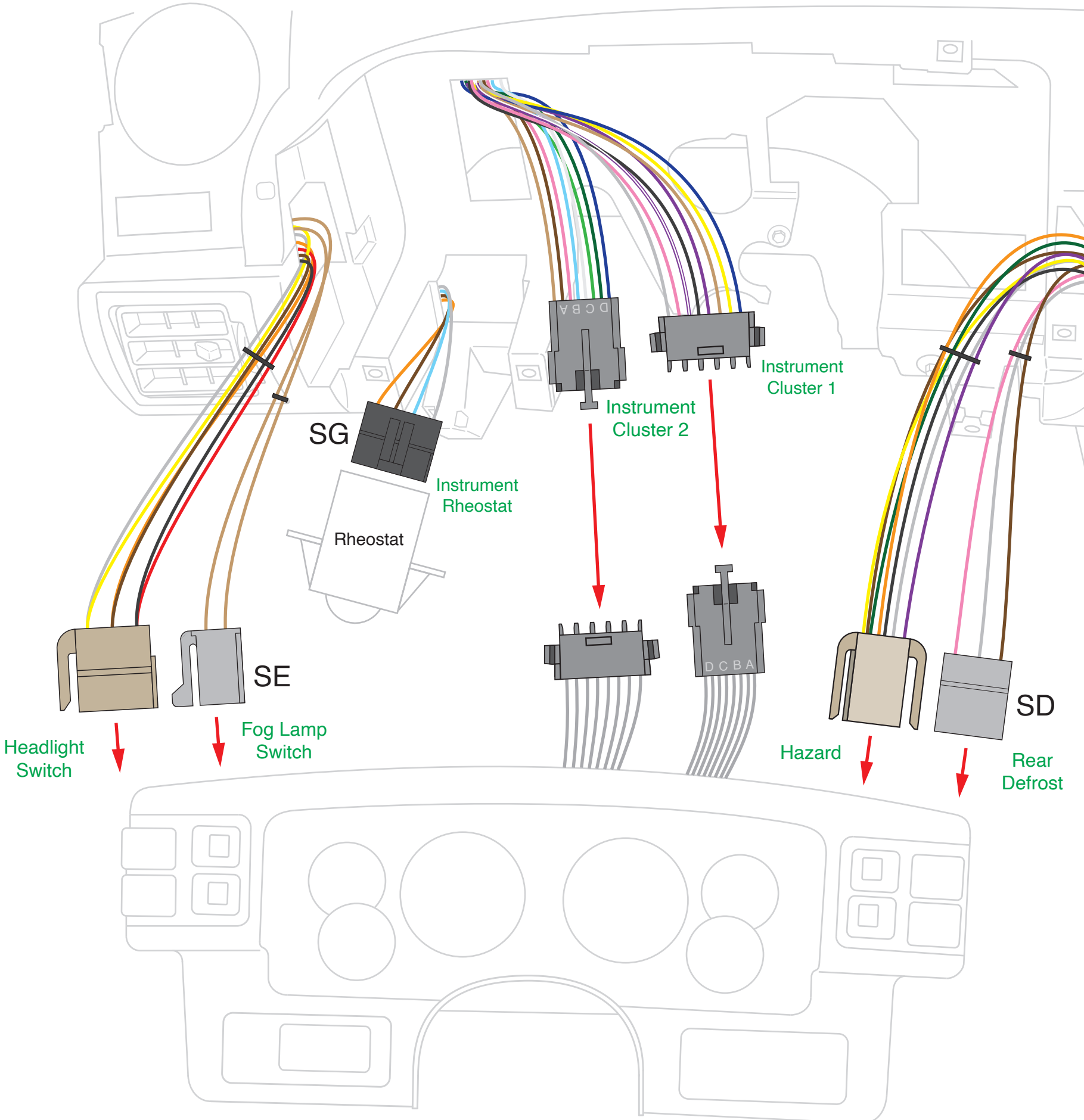

See page 15.



www.americanautowire.com 856-933-0801

1987-89 Ford Mustang
Classic Update Series

510547 92970659 Rev 3.0 JDM 06/30/2023

Rear Body Harness installation instructions:

Shown below, is the side marker lamp socket you will need to salvage/remove from both sides of your original Rear Body harness, that will be re-used (along with the supplied parts below) to complete your Rear Body harness connections. It is itemized and referred to on this page, just as it is on the following pages of this Rear Body instruction set.

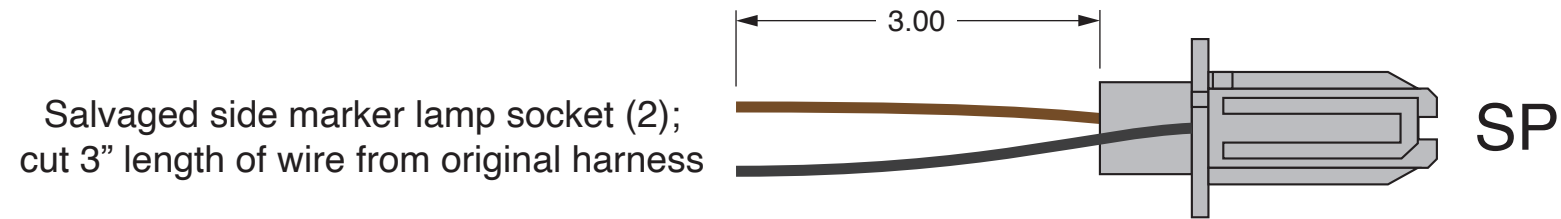

Shown below, are the supplied misc. terminals and plastic connector bodies, that will be used to complete your Rear Body harness connections. They are itemized and referred to on this page, just as they are on the following pages of this Rear Body instruction set.

- | | | | | | |
|---|--|---|---|--|--|
| A | | (56 series 6-way female conn, 1 pc.) | H | | (56 series single male terminal, for smaller gauge wire, 7 pcs.) |
| B | | (56 series single female terminal, 14 pcs.) | J | | (56 series 2-way female conn, 1 pc.) |
| C | | (56 series double female terminal, 3 pcs.) | K | | (56 series 2-way male conn, 1 pc.) |
| D | | (56 series 2-way female conn, 2 pcs.) | L | | (56 series 3-way male conn, 1 pc.) |
| E | | (56 series 1-way female conn, 3 pcs.) | M | | (small single female terminal, 3 pcs.) |
| F | | (56 series 3-way female conn, 2 pcs.) | N | | (56 series single male terminal, for larger gauge wire, 1 pc.) |
| G | | (56 series 1-way male conn, 3 pcs.) | P | | (ring terminal, 2 pcs.) |



Rear Body Harness installation instructions:

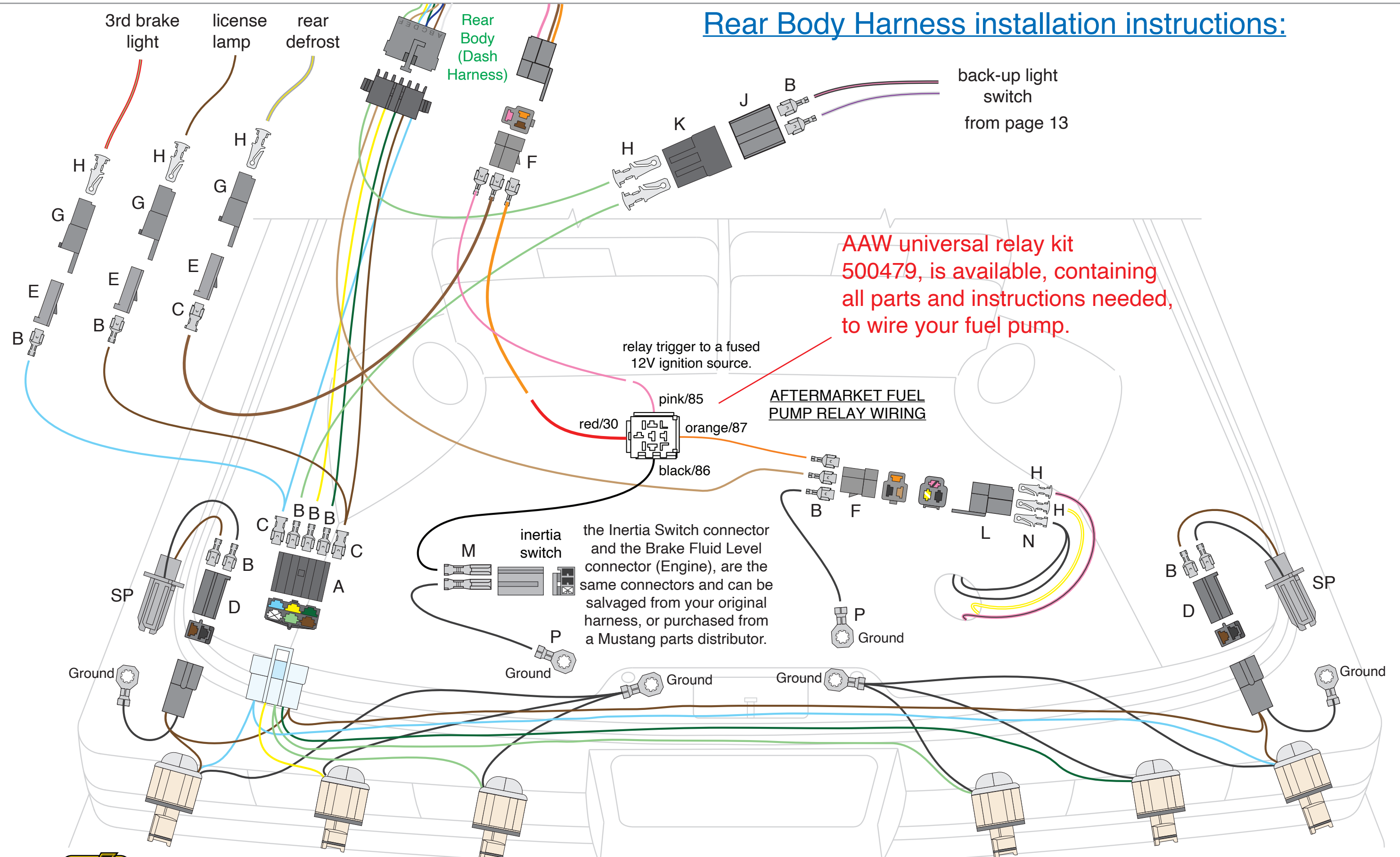

AAW universal relay kit 500479, is available, containing all parts and instructions needed, to wire your fuel pump.

relay trigger to a fused 12V ignition source.

AFTERMARKET FUEL PUMP RELAY WIRING

M inertia switch
 the Inertia Switch connector and the Brake Fluid Level connector (Engine), are the same connectors and can be salvaged from your original harness, or purchased from a Mustang parts distributor.









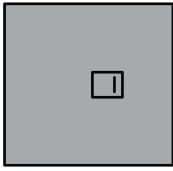

The stop/tail, turn, and back-up sockets in the rear body harness all use **3157** bulbs (not included). These can be sourced from your local parts supplier.

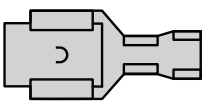
1987-89 Ford Mustang
 Classic Update Series
510547 92970659 Rev 3.0 JDM 06/30/2023

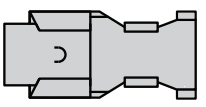

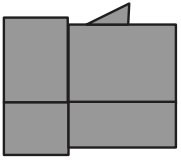
Front Light Harness installation instructions:

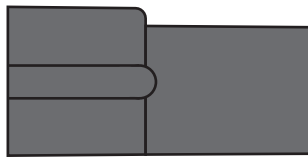
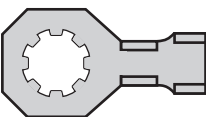
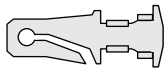
Shown below, are the supplied misc. terminals and plastic connector bodies, that will be used to complete your Front Light harness connections. They are itemized and referred to on this page, just as they are on the following pages of this Front Light instruction set.

- | | | | | | |
|---|---|--|---|---|--|
| A |  | (56 series 4-way female conn, 2 pcs.) | H |  | (sleeve, 4 pcs.) |
| B |  | (56 series single female terminal, 9 pcs.) | J |  | (single female terminal, 2 pcs.) |
| C |  | (56 series double female terminal, 5 pcs.) | K |  | (washer pump conn, 1 pc.) |
| D |  | (56 series 3-way female conn, 1 pc.) | L |  | (56 series 2-way female connector, 2 pcs.) |
| E |  | (56 series 1-way female conn, 2 pcs.) | M |  | (56 series 2-way male connector, 2 pcs.) |
| F |  | (ring terminal, 5 pcs.) | N |  | (56 series single male terminal, 4 pcs.) |
| G |  | (single male terminal, 2 pcs.) | | | |

Front Light Harness installation instructions:

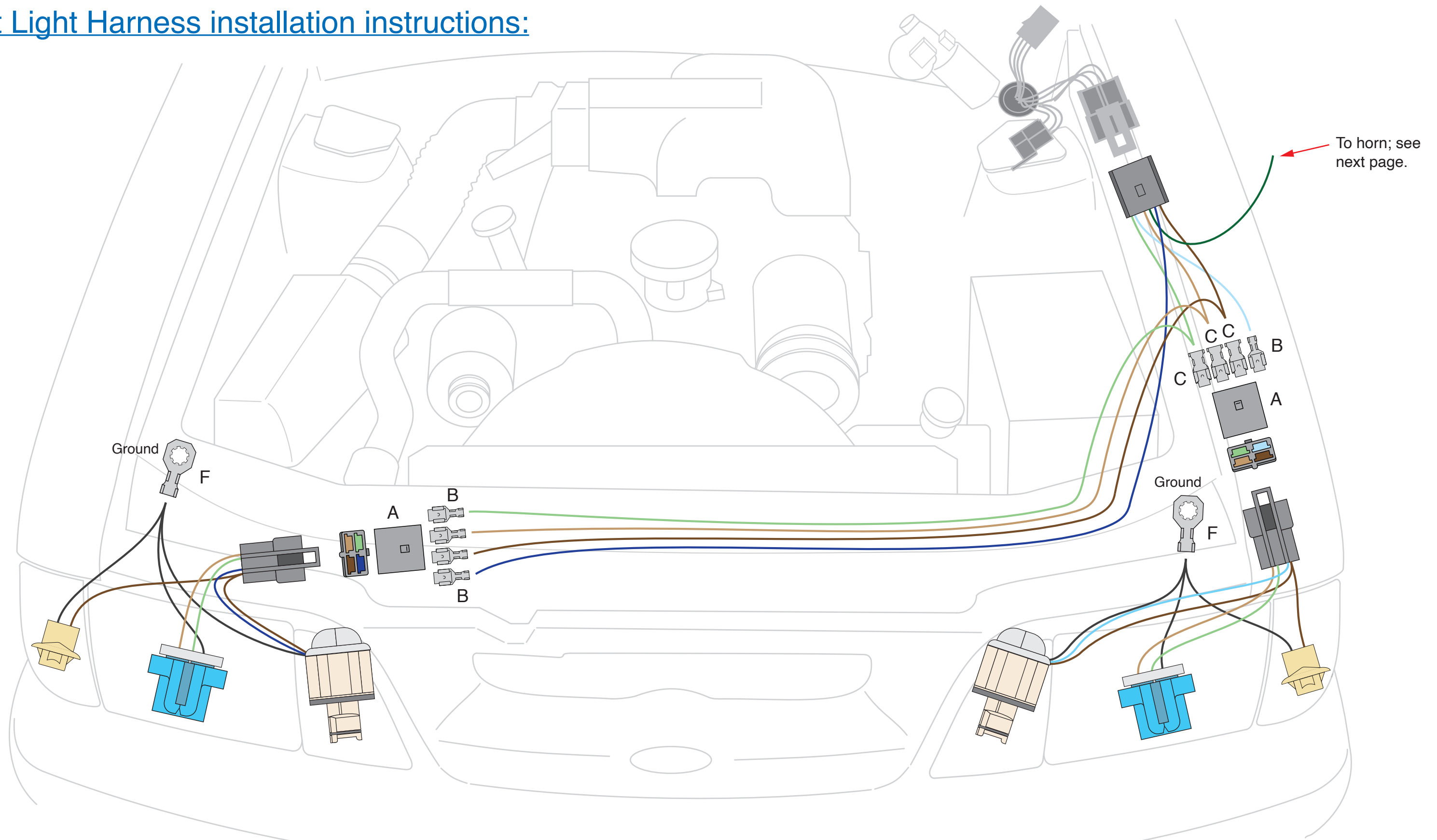

The parking lamp/turn signal sockets in the front light harness use 3157 bulbs (not included). These can be sourced from your local parts supplier.



**American
Autowire**

1987-89 Ford Mustang

Classic Update Series

510547 92970659 Rev 3.0 JDM 06/30/2023

Front Light Harness installation instructions:

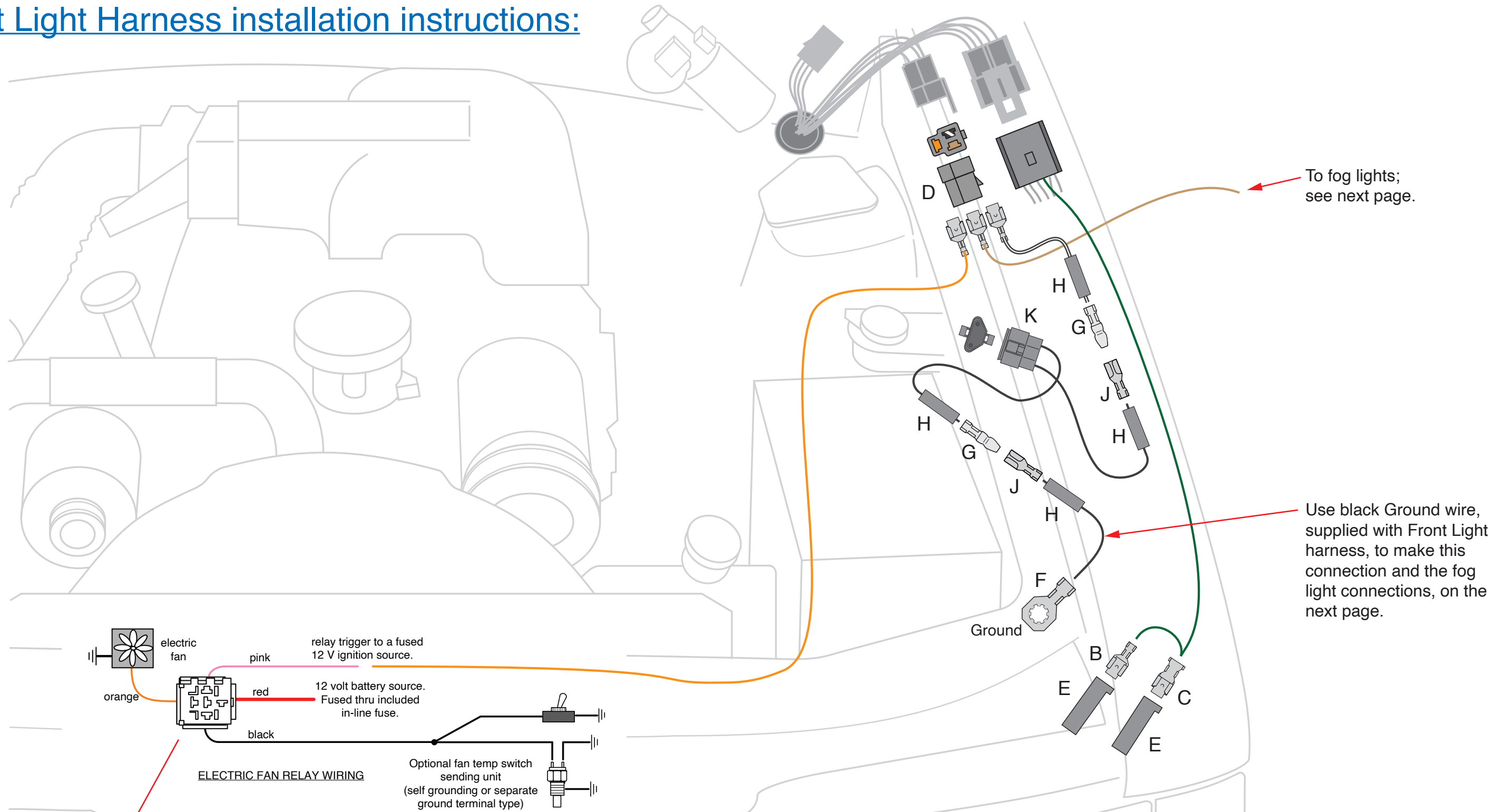

AAW universal relay kit 500479, is available, containing all parts and instructions needed, to wire your electric fan.



www.americanautowire.com 856-933-0801

1987-89 Ford Mustang
Classic Update Series

510547 92970659 Rev 3.0 JDM 06/30/2023

Front Light Harness installation instructions:

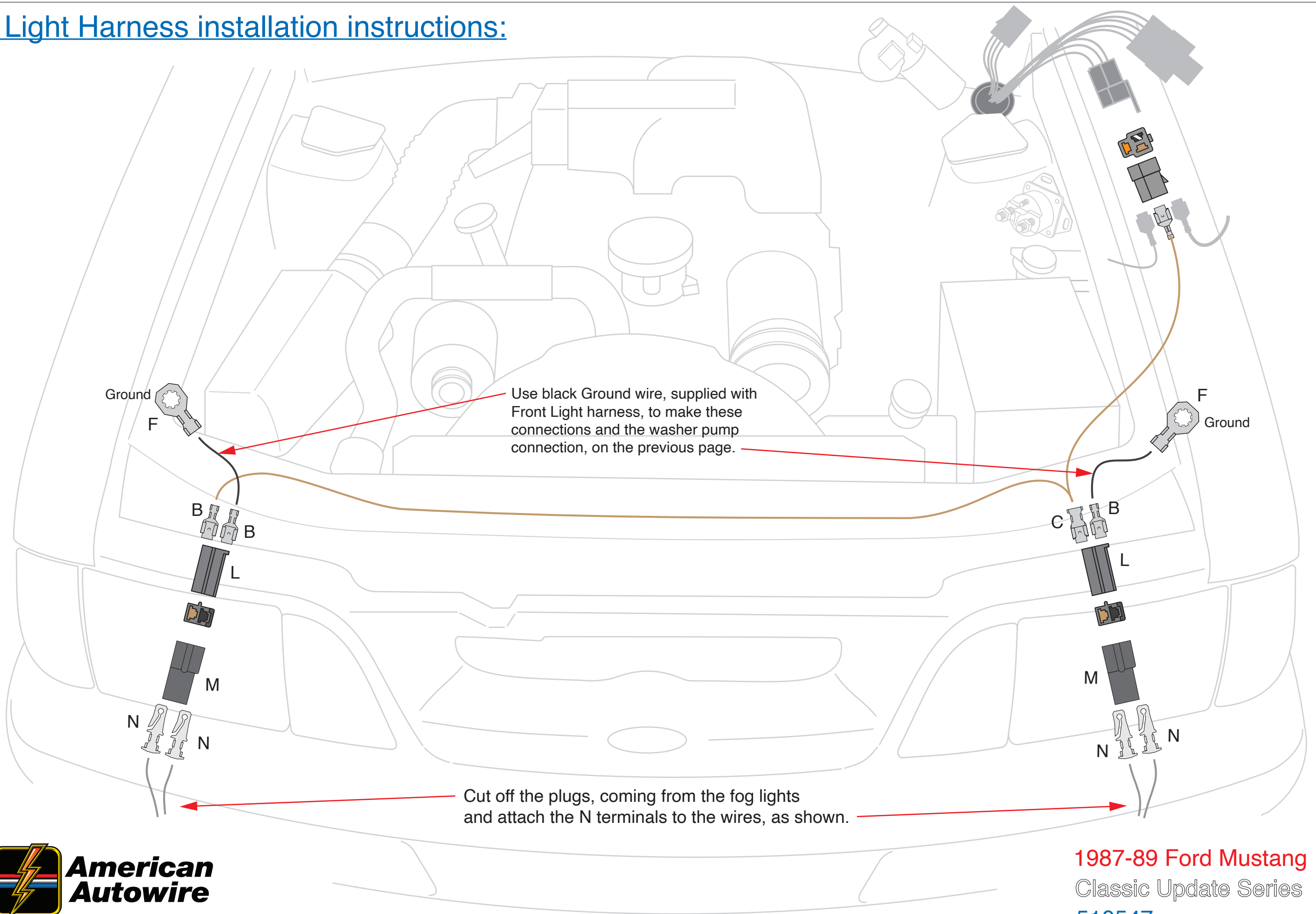

Engine Harness installation instructions:

Shown below, are the supplied misc. terminals, sleeves and plastic connector bodies, that will be used to complete your Engine harness connections. They are itemized and referred to on this page, just as they are on the following pages of this Engine instruction set.

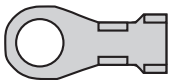
A  (small ring terminal for larger gauge wire, 1 pc.)

B  (small rubber sleeve, 3 pcs.)

C  (56 series single female terminal, 4 pcs.)

D  (56 series single female connector, 2 pcs.)

E  (56 series single male terminal, 2 pcs.)

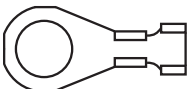
G  (small ring terminal for smaller gauge wire, 4 pcs.)

H  (large rubber sleeve, 2 pcs.)

J  (single male terminal, 1 pc.)

K  (single female terminal, 1 pc.)

L  (10-32 nut, 1 pc.)

M  (56 series 2-way male connector, 1 pc.)

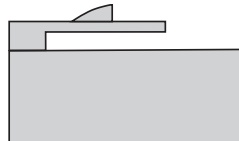
N  (56 series 2-way female connector, 1 pc.)

R  (A/C pressure switch connector, 1 pc.)

T  (large ring terminal, copper, 1 pc.)

U  (small ring terminal for larger gauge wire, copper, 1 pc.)

V  (small single female terminal, 3 pcs.)

W  (ring terminal, 1 pc.)



Engine Harness installation instructions:

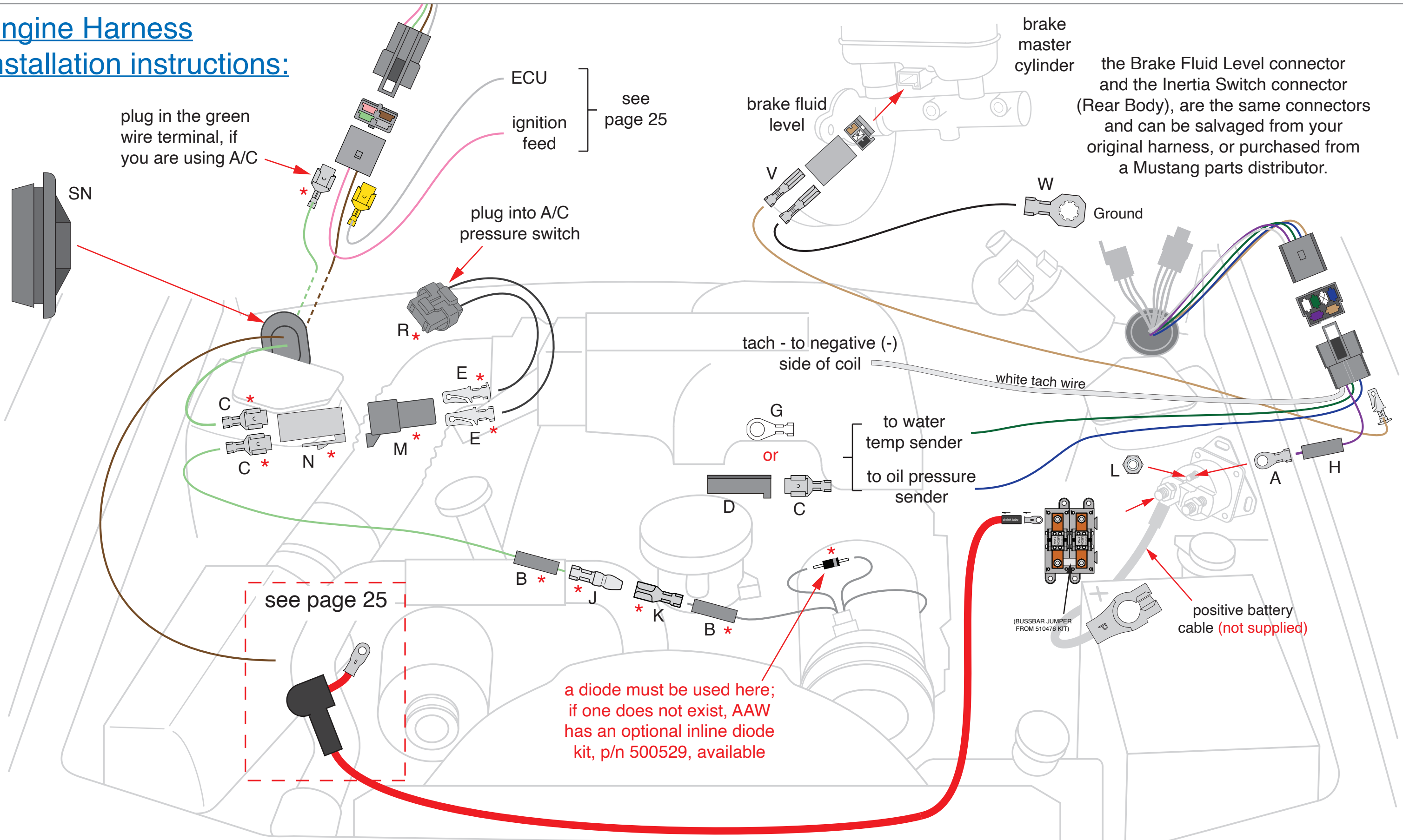

**American
Autowire**

* - if you are not planning on using Air Conditioning, these items are not required.

1987-89 Ford Mustang
Classic Update Series

Engine Harness installation instructions:

Alternator connections:

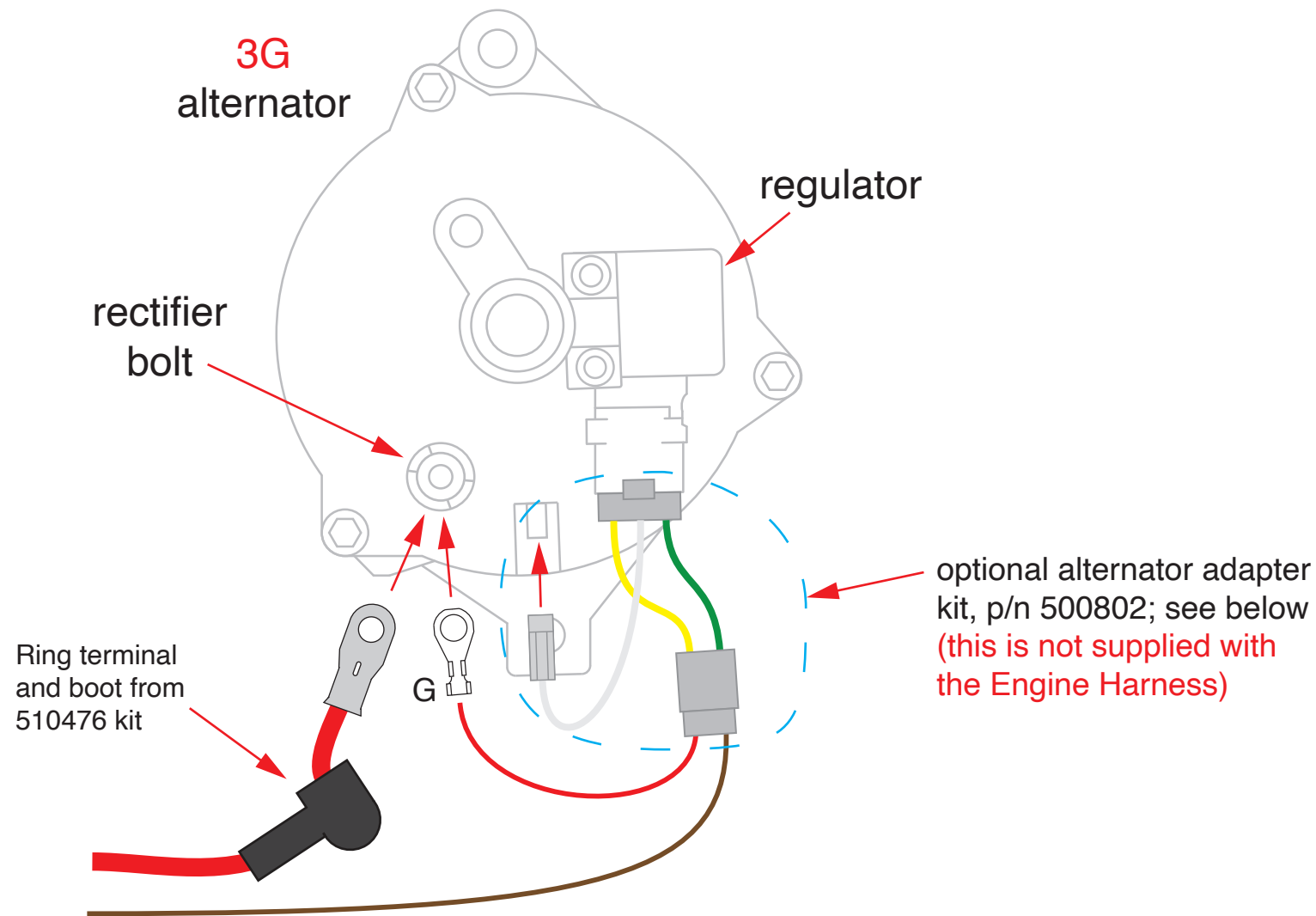

Ring terminal and boot from 510476 kit

optional alternator adapter kit, p/n 500802; see below (this is not supplied with the Engine Harness)

NOTE:
AAW recommends the use of Ford 3G or other alternators, over the use of Ford 2G alternators, due to known failures in 2G alternator wiring.

p/n 500802

GM "SI" series to Ford "3G" internal regulated alternator

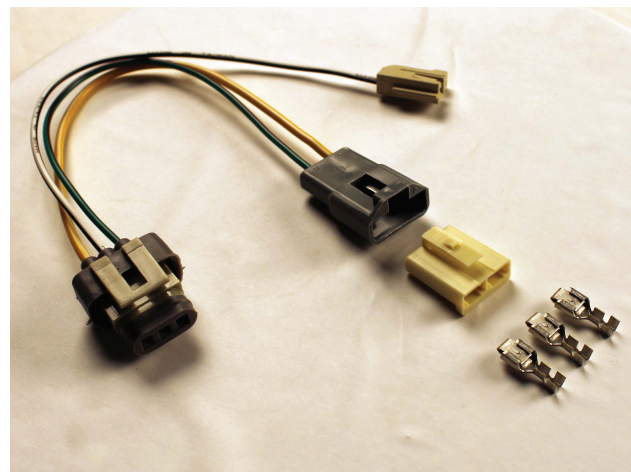

ECU power connections:

The following wires are supplied with this kit, for powering aftermarket ignition systems and fuel injection ECU's.

- Pink - 12v in run and crank key positions - This wire is already installed in the Engine Kit 51056
- Grey - 12v in the run key position - This wire is supplied loose and needs to be plugged into the location shown page 24, if required.
- Purple - 12v in crank key position - This wire is supplied loose and can be connected to the S terminals of the starter solenoid and connected to your ECU if required.
- Orange - 12v constant battery power - This wire is supplied loose and needs to be connected Main Power Feed side of the Mega Fuse, if required.

Please refer to your ignition system or fuel injection manufacturer's instructions, for correctly connecting to the system that you are using.

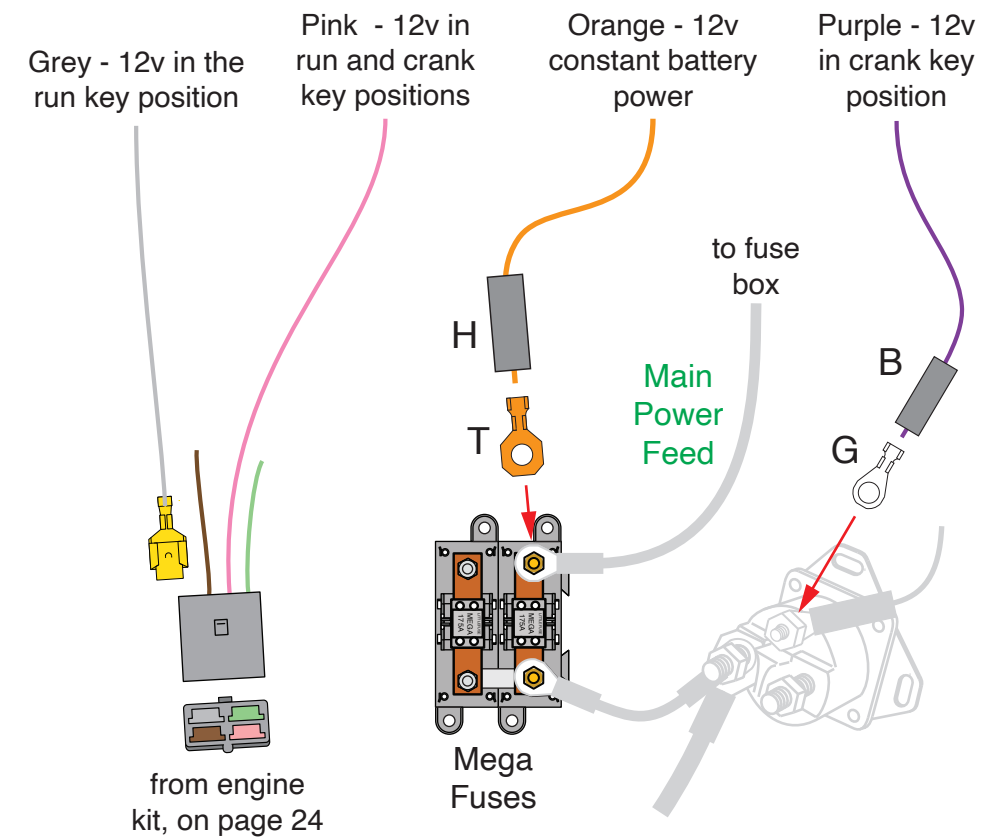

1987-89 Ford Mustang

Classic Update Series

510547 92970659 Rev 3.0 JDM 06/30/2023



STEP 3: RECONNECT YOUR BATTERY:

When you have completed the installation and are ready to reconnect the battery, make sure that the following electrical system grounds are in place:

- A. Battery is grounded to the ENGINE BLOCK.
- B. Battery is grounded to the frame.
- C. Engine block is grounded to the frame.
- D. Body is grounded to the frame.

STEP 4: CHECK ALL ELECTRICAL FUNCTIONS:

Any non-functioning items should be checked for proper installation. Any problems with your wiring and electrical circuit functions, should be addressed to American Autowire Systems, Inc. as soon as possible, to avoid any warranty problems.

If you have any questions concerning this or any of our products, please feel free to call us at 1-856-933-0801.

